

External Holders

D



D1 ~ D38











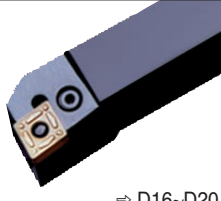

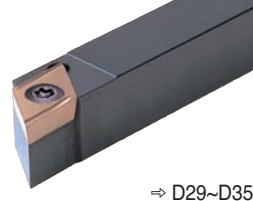

External Holders

Selection	Turning Holder Serie	D2 - 5
ISO	Turning Holder Identification Table	D6
	Calculation of The Cutting Edge Position	D7
T-REX Tool Holders	SumiTurn T-REX Tool Holders	D8 - 9
For High Performance Turning	D Type Double Clamp Holders	
	New DC Type Holders	D10
	DD Type Holders	D11
	New DS Type Holders	D12
	DT Type Holders	D13
	DV Type Holders	D14
	DW Type Holders	D15
General Turning	P Type Lever Lock and M Type Top & Hole Clamp Holders	
	PC Type Holders	D16
	PD Type Holders	D17
	PS Type Holders	D18-19
	PT / MT Type Holders	D20-21
	PW / MW Type Holders	D22
For Solid CBN Inserts	C Type Clamp On Holders	D23-24
	X Type Dimple Lock Holders	D25
Selection	Mini Holders Series	D26-27
Special for Back Facing	SBT Type Mini Holders	D28
Small Product Turning	PC / SC Type Mini Holders	D29
	PD / SD Type Mini Holders	D30-31
	PR Type Holders	D32
	New SR Type Holders	D33
	SS Type Mini Holders	D34
	ST Type Mini Holders	D35
	SV Type Copying Holders	D36-37

External Tool Holder Series

According to Applications

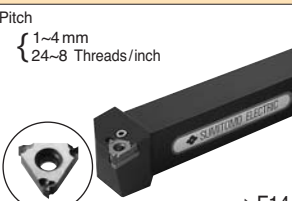
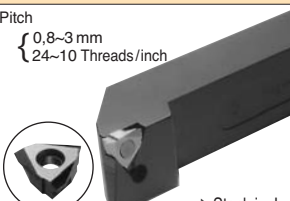
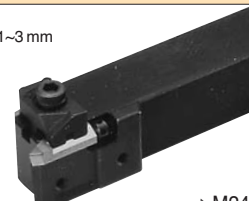
Application	Economical Type for Neg. Inserts	Economical Type for Pos. Inserts	Special Type for Hardened Steel
General Turning	P Type Lever Lock Type  ⇒ D16~D20	P Type Lever Lock Type  ⇒ D29, D30	D Type Double Lock Type  ⇒ D10~D15
	M Type Double Lock Type  ⇒ D21~D22	S Type Screw On Type  ⇒ D29~D35	C Type Top Clamp Type  ⇒ D23~D25
	T-REX  ⇒ D8~D9	S Type Screw On Type  ⇒ D36~D37	D Type Double Lock Type  ⇒ D11, D14
	SCT and GWC Type  ⇒ F2~F4	Sumi Grip and Sumi Grip Jr.  ⇒ F6~F10	GWB Type  ⇒ M23
Parting-Off Grooving	LTE and STE Type Pitch { 1~4 mm { 24~8 Threads/inch  ⇒ F14	THE Type Pitch { 0.8~3 mm { 24~10 Threads/inch  ⇒ Stock in Jp.	BNGG-TT Type Pitch 1~3 mm  ⇒ M24
Threading			

Ext. Turning

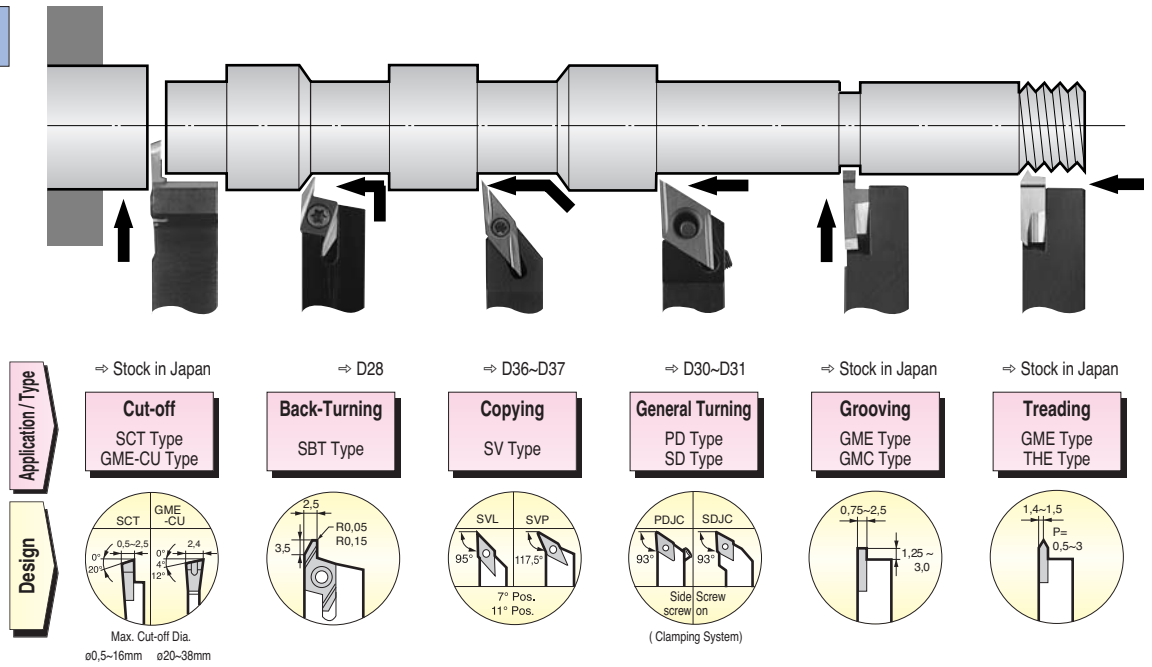

External Holders

Holder Selection for Autolathe

	Offset - 0 mm Type Holders	Offset - 0,5 mm Type Holders
Tooling		
Features	Program correction is not necessary.	The position of cutting edge can be put in near guide bush through a program correction.
Holder Types	SDJC-X, SDAC-X SDLX-X, SCAC-X SVJC-X (⇒ Lager in Japan)	PDJC, SDJC, SDAC PCLC, SCAC STAC, SVLC



External Tool Holder Series



X Type "Dimple Lock" Holder
XSBN-R 2525 N12
for special solid CBN and ceramic inserts

TOOLING SELECTION

External Holders

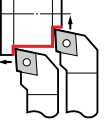
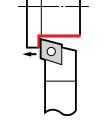
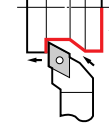
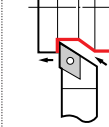
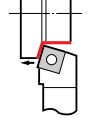
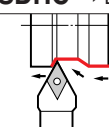
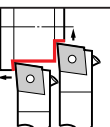
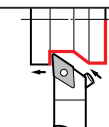
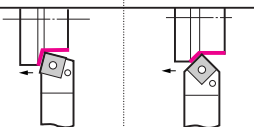
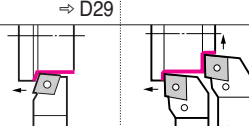
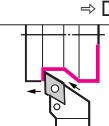
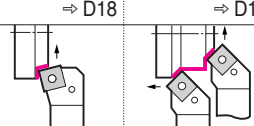
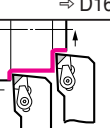
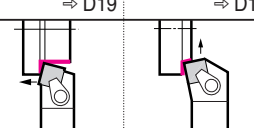
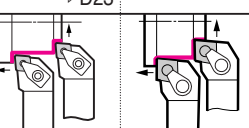
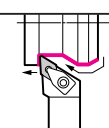
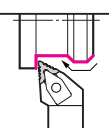
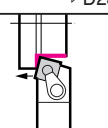
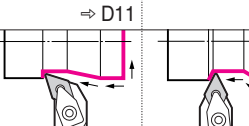
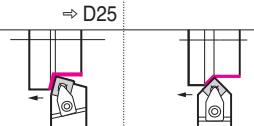
Application		General Turning & Facing	General Turning & Copying		General Turning		
			80° Diamond Type	55° Diamond Type	T-REX 55°	90° Square Type	
Insert Type System		80° Diamond Type		55° Diamond Type	T-REX 55°	90° Square Type	
Screw Lock System	S Type Mini Holder	 SCLC ⇒ D29	 SCAC ⇒ D29	 SDJC ⇒ D30 SDHC ⇒ D30	 SDAC ⇒ D31	—	 SSBC ⇒ D34
		—	—	 SDNC ⇒ D31	—	—	—
Lever Lock System	P Type (* Side Lever Lock Type)	 PCLC (*) ⇒ D29	—	 PDJC (*) ⇒ D29	—	—	 PSBN ⇒ D18 PSDN ⇒ D18
		 PCBN ⇒ D16 PCLN ⇒ D16	 PDJN ⇒ D17	—	—	 PSKN ⇒ D19 PSSN ⇒ D19	
Top-On Clamp System	C & M Type	 CCLN ⇒ D23	—	—	—	—	 CSBN ⇒ D23 CSKN ⇒ D23
Double Lock (D) Dimple Lock (X)	D & X Type	 DCLN ⇒ D10 XCLN ⇒ D25	 DDJN ⇒ D11	—	 DTR ⇒ D8-9	 XSBN ⇒ D25	—
		—	—	 DDHN ⇒ D11 DDNN ⇒ D11	—	 DSBN ⇒ D12 DSDN ⇒ D12	



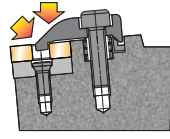



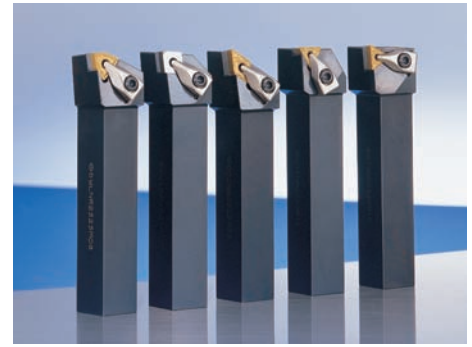

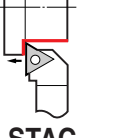
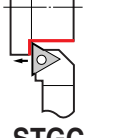
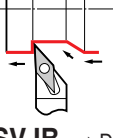
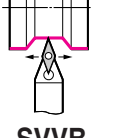
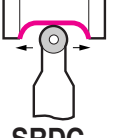
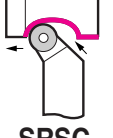
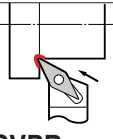
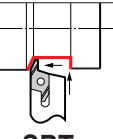
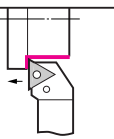
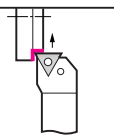
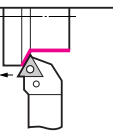
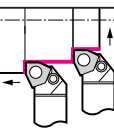
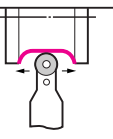
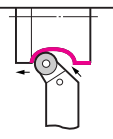

External Tool Holder Series



D Type "Double Clamp" Holders for high performance machining

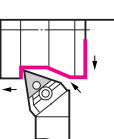
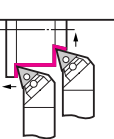

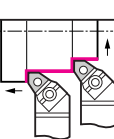
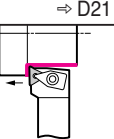
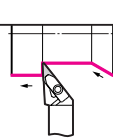
TOOLING SELECTION

Application		General Turning			Copying		General Turning	Special Turning	
Insert Type		60° Triangle Type			35° Diamond Type		80° Trigon Type	Round and Special Purpose Inserts	
System									
Screw Lock System	S Type Mini Holder	 STAC ⇒ D35	 STGC ⇒ D35	—	 SVJB SVLC ⇒ D36 ⇒ D37	 SVVB ⇒ D36	—	 SRDC ⇒ D33	 SRSC ⇒ D33
		—	—	—	 SVPB SVPC ⇒ D36 ⇒ D37	—	—	 SBT ⇒ D28	—
Lever Lock System	P Type	 PTGN ⇒ D20	 PTFN ⇒ D20	 PTTN ⇒ D20	—	—	 PWLN ⇒ D22	 PRDC ⇒ D32	 PRGC ⇒ D32
		—	—	—	—	—	—	—	—
Top-On Clamp System	C & M Type	 MTJN ⇒ D21	 MTXN ⇒ D21	—	—	—	 MWLN ⇒ D22	 CRDN ⇒ D24	 CRSN ⇒ D24
		—	—	—	—	—	—	—	—
Double Lock (D) Dimple Lock (X)	D & X Type	 DTJN ⇒ D13	 DTFN ⇒ D13	—	 DVJN ⇒ D14	—	 DWLN ⇒ D15	—	—
		 DTGN ⇒ D13	—	—	 DVQN ⇒ D14	 DVVN ⇒ D14	—	—	—

ISO Holders Identification

■ Catalogue Classification System For SEC-Tool Holders

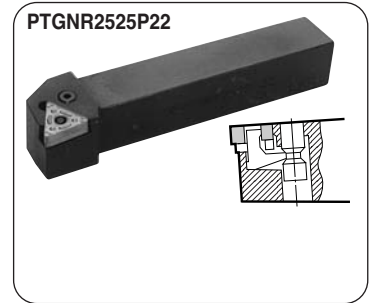
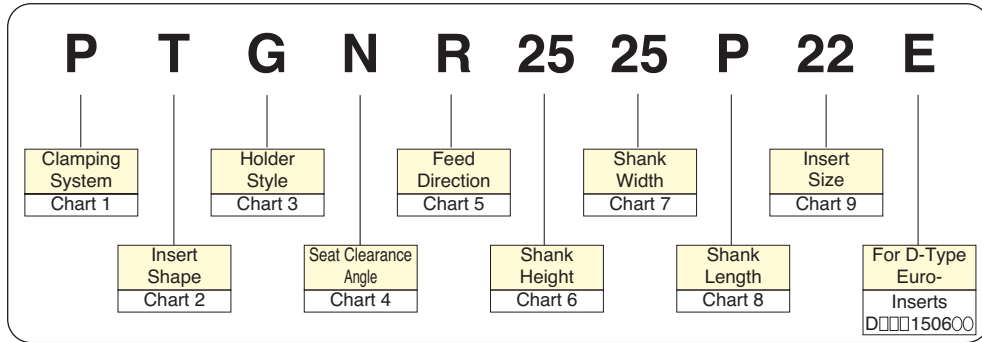

External Holders

Chart 1

Clamping System					
Symbol	Clamp Types	Example of Structure	Symbol	Clamp Types	Example of Structure
C	Top Clamp		M	Top & Hole Clamp Type	
D	Double Clamp		P	Lever Lock Type (Insert is supported by 1 face)	
E	Pin Lock Type (Insert is supported by 1 face)		S	Screw Clamp Type	

Chart 5

Feed Direction	
Symbol	
R	Right Hand Feed
L	Left Hand Feed
N	Neutral Feed

Chart 2

Insert Shape					
Symbol	Insert Shape	Symbol	Insert Shape	Symbol	Insert Shape
A	Parallelogram 85°	M	Rhombic 86°		
B	Parallelogram 82°	O	Octagonal		
C	Diamond 80°	P	Pentagonal		
D	Diamond 55°	R	Round		
E	Diamond 75°	S	Square		
F	Diamond 50°	T	Triangular		
H	Hexagonal	V	Diamond 35°		
K	Parallelogram 55°	W	Trigon		
L	Rectangular				

Chart 4

Seat Clearance Angle	
Symbol	Relief Angle
A	3°
B	5°
C	7°
D	15°
E	20°
F	25°
G	30°
N	0°
P	11°
O	Special Angle

Chart 3

Holder Style					
Symbol	Shape	Offset	Symbol	Shape	Offset
A		Nil	L		With Offset
B		Nil	N		Nil
D		Nil	R		With Offset
E		Nil	S		With Offset
F		With Offset	T		With Offset
G		With Offset	U		With Offset
J		With Offset	W		With Offset
K		With Offset	Y		With Offset

Chart 6

Shank Height		Shank Width	
Symbol	Height (mm)	Symbol	Width (mm)
	12		12
	16		16
	20		20
	25		25
	32		32
	40		40
	50		50
00	Round shank,		Shank Diameter is Shown for Round Shank,

2 digits are used for each dimension in mm.

Chart 7

Chart 8

Shank Length	
Symbol	Length (mm)
F	80
H	100
K	125
M	150
N	160
P	170
Q	180
S	250
T	300
U	350

For some Products, a Hyphen is used Instead of an alphabet.

Chart 9

Cutting Edge	
Symbol	Length (mm)
Eg. for Triangle Inserts:	
06	6,9
08	8,2
09	9,6
11	11,0
16	16,5
22	22,0
27	27,5
33	33,0

For Round Inserts:	
Symbol	Length (mm)
10	10
12	12
16	16
20	20
25	25
32	32

■ Cutting Edge Dimensions by Corner Radius

(This table shows X and Y dimensions based on 0° approach angle cutting edge inclination)

Holders			Dimensions(mm)			Holders			Dimensions(mm)		
Symbol	Shapes	Corner Shapes	R	X	Y	Symbol	Shapes	Corner Shapes	R	X	Y
A			0,4	0,291	-	K			0,4	0,024	0,089
			0,8	0,581	-				0,8	0,048	0,178
			1,2	0,872	-				1,2	0,072	0,268
			1,6	1,162	-				1,6	0,096	0,357
			2,4	1,743	-				2,4	0,143	0,535
B			0,4	0,089	0,024	L			0,4	0,040	0,040
			0,8	0,178	0,048				0,8	0,079	0,079
			1,2	0,268	0,072				1,2	0,119	0,119
			1,6	0,357	0,096				1,6	0,159	0,159
			2,4	0,535	0,143				2,4	0,238	0,238
D			0,4	0,164	0,164	N			0,4	0,463	0,263
			0,8	0,329	0,329				0,8	0,925	0,471
			1,2	0,493	0,493				1,2	1,388	0,707
			1,6	0,658	0,658				1,6	1,850	0,943
			2,4	0,986	0,986				2,4	2,776	1,414
E			0,4	0,396	0,229	S			0,4	0,164	0,164
			0,8	0,793	0,458				0,8	0,329	0,329
			1,2	1,190	0,687				1,2	0,493	0,493
			1,6	1,587	0,916				1,6	0,658	0,658
			2,4	2,381	1,374				2,4	0,986	0,986
F			0,4	-	0,291	T			0,4	0,396	0,229
			0,8	-	0,581				0,8	0,793	0,458
			1,2	-	0,872				1,2	1,190	0,687
			1,6	-	1,162				1,6	1,587	0,916
			2,4	-	1,743				2,4	2,381	1,374
G			0,4	0,291	-	U			0,4	0,253	0,058
			0,8	0,581	-				0,8	0,506	0,116
			1,2	0,872	-				1,2	0,759	0,175
			1,6	1,162	-				1,6	1,013	0,233
			2,4	1,743	-				2,4	1,519	0,350
J			0,4	0,344	0,033	Y			0,4	0,002	0,033
			0,8	0,687	0,079				0,8	0,005	0,066
			1,2	1,031	0,118				1,2	0,008	0,099
			1,6	1,375	0,157				1,6	0,011	0,132
			2,4	2,062	0,236				2,4	0,017	0,198

External Holders

● Calculation of the Nose Radius Dimensions

(Unit in mm)

Insert Shape	Calculation
Triangle	$B = \frac{3}{2}A - R$
Square	$B = (\sqrt{2}-1) \times (\frac{A}{2} - R)$
Rhombic	$B = \left\{ \frac{1}{\sin(\theta/2)} - 1 \right\} \times (\frac{A}{2} - R)$

Figures of "A" and "R" to calculate Figure "B"

I.C. size (inch)	"A" dimensions (mm)	Nose symbol	Size (inch)	"R" dimension (mm)
-	5/32	02	(0)	0,203
-	6/32	04	1/64	0,397
-	7/32	08	2/64	0,794
2/8	8/32	12	3/64	1,191
-	(0)	16	4/64	1,588
3/8	-	24	6/64	2,389
4/8	-			
5/8	-			
6/8	-			
8/8	-			

SumiTurn T-REX Tool Holders

RIGIDITY - ECONOMY - PRECISION

The Biting Force Behind



External Holders
for neg. Inserts



- T-REX clamping for maximum rigidity 50% more cutting edges than a DNMG Insert

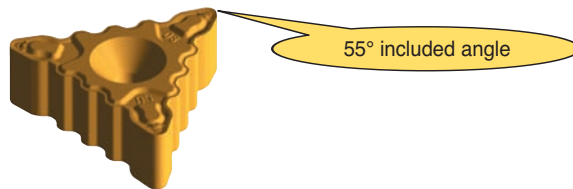

Advantages

● T-REX Inserts for Maximum Economy

With 6 cutting edges and a 55 degree included angle - T-Rex is the intelligent alternative to profile turning with a traditional 4 edge DNMG insert.

● Biting Performance from T-REX Teeth

The double clamp tool holder and powerful teeth of T-REX lock the insert to eliminate movement, dramatically improving tool life, machining accuracy, and cutting edge security.

Application Range

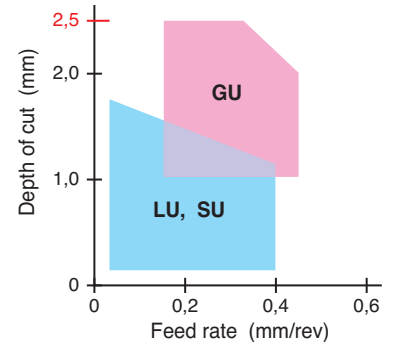
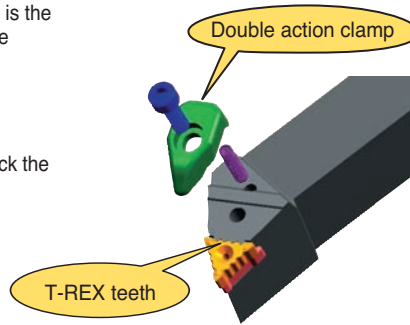

Application Examples

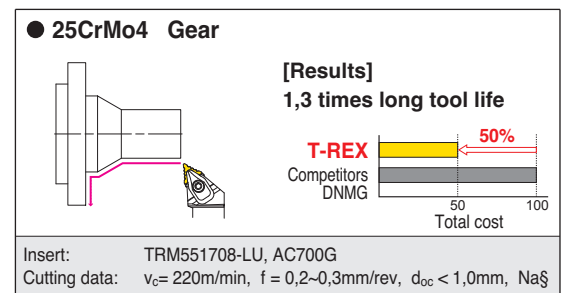
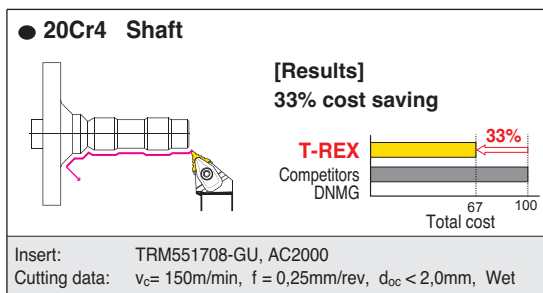

Recommendations

● Depth of Cut

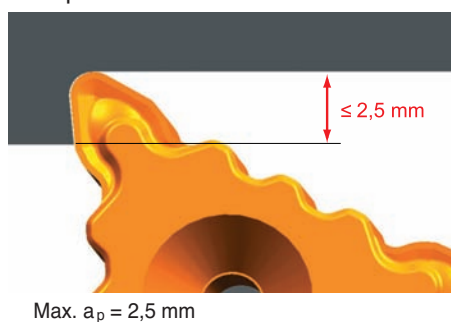

● Approach Angle

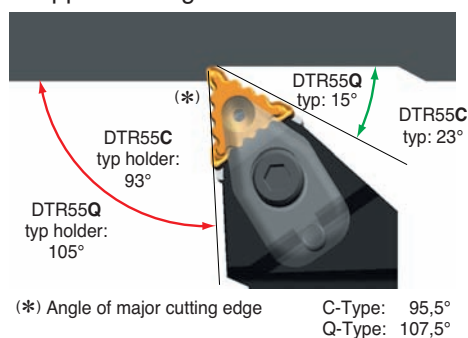

● Insert Clamping

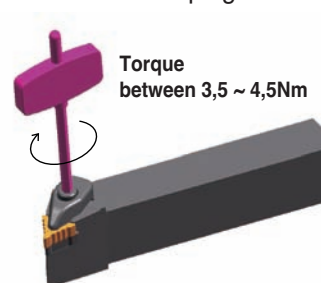

SumiTurn T-REX Tool Holders

SumiTurn

External Turning & Copying

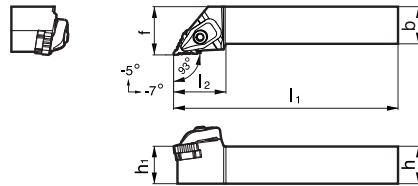
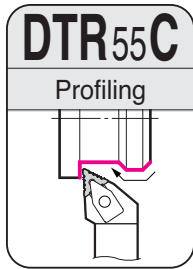

■ Holders

Above figures show right hand tools.

Ordering No.	Stock		Dimensions (mm)					
	R	L	h	h ₁	b	l ₁	l ₂	f
DTR55C R/L 2020-K17	●	●	20	20	20	125	35	25
DTR55C R/L 2525-M17	●	●	25	25	25	150	35	32

■ Spare Parts

Clamp	Spring	Screw	Shim	Screw	Wrench	Wrench
TRCP3	S-SP4-20	BX0520	TRW5505	BFTX0307N	TSW040	TRX10 ^(*)

^(*) Note: Wrench (TRX) for shim clamp screw is not included.

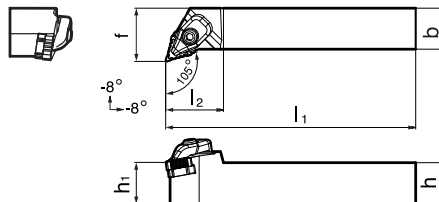
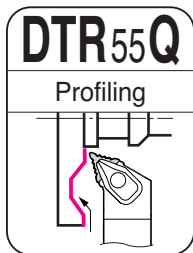

■ Holders

Above figures show right hand tools.

Ordering No.	Stock		Dimensions (mm)					
	R	L	h	h ₁	b	l ₁	l ₂	f
DTR55Q R/L 2020-K17	●	●	20	20	20	125	35	28,5
DTR55Q R/L 2525-M17	●	●	25	25	25	150	35	32

■ Spare Parts

Clamp	Spring	Screw	Shim	Screw	Wrench	Wrench
TRCP3	S-SP4-20	BX0520	TRW5505	BFTX0307N	TSW040	TRX10 ^(*)

^(*) Note: Wrench (TRX) for shim clamp screw is not included.

■ Inserts

● Type LU



Application **P** Steel
M Stainless steel

● Type SU



Ordering No.	r	Coated Carbide						Coated Cermet		
		AC700G	AC900G	AC820P	AC830P	AC2000	AC3000	AC610M	AC630M	T2000Z
TRM 551704 -LU	0,4	●	●	●	▲	▲			●	●
TRM 551708 -LU	0,8	●	●	●	▲	▲			●	●
TRM 551712 -LU	1,2	●	●	●	▲	▲			●	●
TRM 551704 -SU	0,4			●			●	●	●	●
TRM 551708 -SU	0,8			●			●	●	●	●
TRM 551712 -SU	1,2			●			●	●	●	●

● Type GU

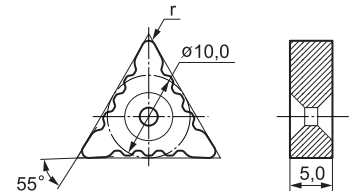

Ordering No.	r	Coated Carbide						Coated Cermet		
		AC700G	AC900G	AC820P	AC830P	AC2000	AC3000	AC610M	AC630M	T2000Z
TRM 551704 -GU	0,4	●	●	●	▲	▲			●	●
TRM 551708 -GU	0,8	●	●	●	▲	▲			●	●
TRM 551712 -GU	1,2	●	●	●	▲	▲			●	●

● Recommended Cutting Conditions

— Cutting speed (m/min)

Grade		Coated Carbide						Coated Cermet	
		AC700G	AC900G	AC820P (AC2000)	AC830P (AC3000)	AC610M	AC630M	T2000Z	T3000Z
Work materials	Low carbon steel	220 350	200 300	150 280	90 250			100 350	100 300
	Alloy steel	150 300	150 280	100 250	80 200			100 300	100 250
	Stainless steel				50 150	130 210	100 160		
Application range	Finishing	○	○	○	○	○	○	○	○
	Medium cutting	○	○	○	○	○	○	○	○
	Interrupted cutting			○	○		○		○

◎ 1-st recommendation ○ 2-nd recommendation

● = Euro stock

Packing unit and ordering example; 1 pce DTR55CR2020-K17 (R: right handed)

External Holders
for neg. Inserts

External Tool Holders D Type (Double Clamp)

Tool Holders for neg. Inserts CN__

General Turning and Facing

New

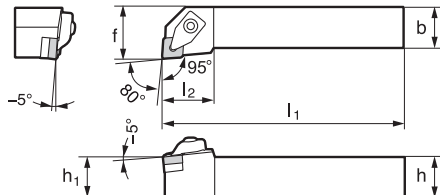
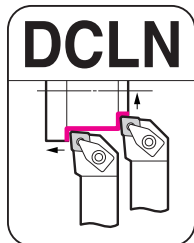
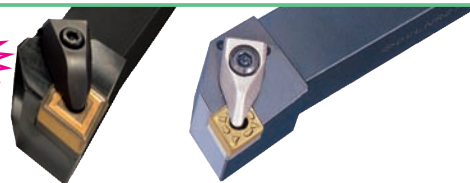

■ Inserts

Eg.

N-GU

- ① CNMG 120408 N-GU
- ② CNMM 190612 N-HG
- ③ CNMM 250924 N-HU

■ Spare Parts

Clamp	Spring	Clamp bolt	Shim	Shim Screw	Wrench (TRX / TRD)	Wrench	Insert
	SCP-2		CNS1204	BFTX0409N	TRX15 ^(*)	LH040	①
	SCP-5		CNS1906	BFTX0511N	TRX20 ^(*)	LH040 LH025	②
	SCP-6		CNS2509	BFTX0615N	TRD25 ^(*)	LH060, LH025	③

^(*) Note: Wrench (TRX / TRD) for shim clamp screw is not included.

■ Holders

Above figures show right hand tools.

Ordering No.	Stock		Dimensions (mm)						
	R	L	h	h ₁	b	l ₁	l ₂	f	
DCLN R/L 2020 K12	●	●	20	20	20	125	32	25	
DCLN R/L 2525 M12	●	●	25	25	25	150	32	32	
New DCLN R/L 3232 P19	●	●	32	32	32	170	42	40	
New DCLN R/L 4040 S19	●	●	40	40	40	250	42	50	
New DCLN R/L 4040 S25	●	●	40	40	40	250	53	50	

External Holders for neg. Inserts

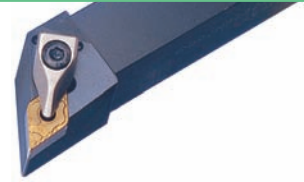

General Turning and Copying

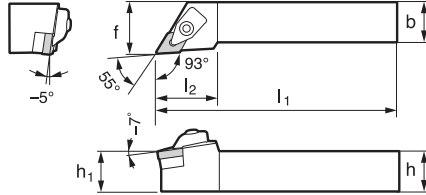
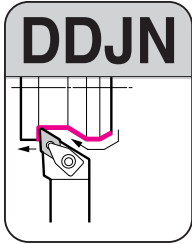

■ Holders

Above figures show right hand tools.

Ordering No.	Stock		Dimensions (mm)					
	R	L	h	h ₁	b	l ₁	l ₂	f
DDJN R/L 2020 K15			20	20	20	125	38	25
DDJN R/L 2020 K15E	●	●	20	20	20	125	38	25
DDJN R/L 2525 M15	○		25	25	25	150	38	32
DDJN R/L 2525 M15E	●	●	25	25	25	150	38	32

■ Inserts



■ Spare Parts

Clamp	Spring	Clamp bolt	Shim	Shim Screw	Wrench	Wrench	Insert
SCP-2			DNS1504	BFTX0409N	TRX15 ^(*)	LH040	1
			DNS1506				2
			DNS1504				1
			DNS1506				2

(*) Note: Wrench (TRX) for shim clamp screw is not included.

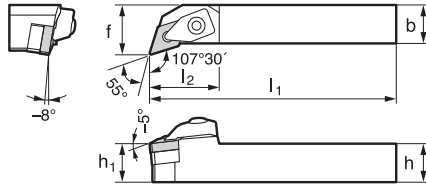
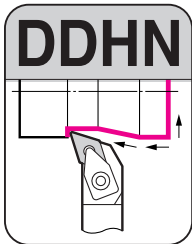

■ Holders

Above figures show right hand tools.

Ordering No.	Stock		Dimensions (mm)					
	R	L	h	h ₁	b	l ₁	l ₂	f
DDHN R/L 2020 K15E	●	●	20	20	20	125	35	25
DDHN R/L 2525 M15E	●	●	25	25	25	150	35	32

■ Inserts

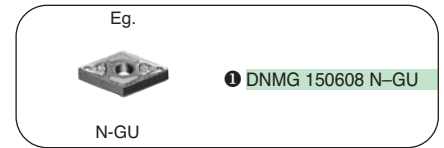

■ Spare Parts

Clamp	Spring	Clamp bolt	Shim	Shim Screw	Wrench	Wrench	Insert
SCP-2			DNS1504	BFTX0409N	TRX15 ^(*)	LH040	1
			DNS1506				

(*) Note: Wrench (TRX) for shim clamp screw is not included.

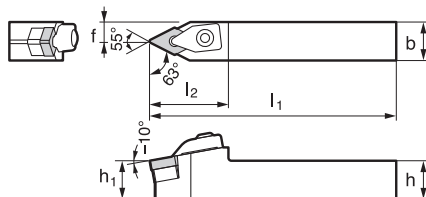
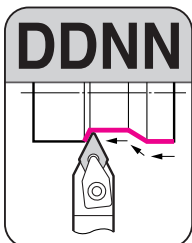

■ Holders

Above figures show right hand tools.

Ordering No.	Stock	Dimensions (mm)					
		h	h ₁	b	l ₁	l ₂	f
DDNN N 2020 K15E	●	20	20	20	125	40	10,5
DDNN N 2525 M15E	●	25	25	25	150	40	13,0

■ Inserts



■ Spare Parts

Clamp	Spring	Clamp bolt	Shim	Shim Screw	Wrench	Wrench	Insert
SCP-2			DNS1504	BFTX0409N	TRX15 ^(*)	LH040	1
			DNS1506				

(*) Note: Wrench (TRX) for shim clamp screw is not included.

External Tool Holders D Type (Double Clamp)

Tool Holders for neg. Inserts SN__

General Turning and Facing

New

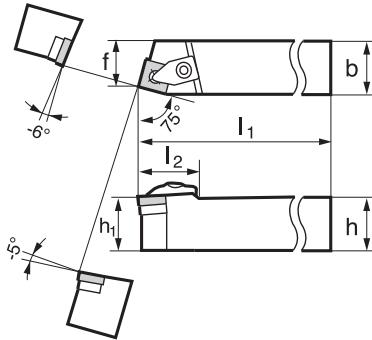
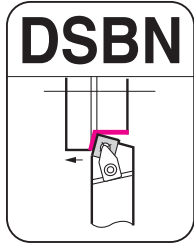

Above figures show right hand tools.

■ Holders

Ordering No.	Stock		Dimensions (mm)					
	R	L	h	h ₁	b	l ₁	l ₂	f
New DSBN R/L 3232 P19	●	●	32	32	32	170	45	27
New DSBN R/L 4040 S2507	●	●	40	40	40	250	58	35
New DSBN R/L 4040 S2509	●	●	40	40	40	250	58	35

■ Inserts

Eg.

N-UZ, N-HU

- ① SNMG 190612 N-UZ
- ② SNMM 250724 N-HU
- ③ SNMM 250924 N-HU

■ Spare Parts

Clamp	Spring	Clamp bolt	Shim	Shim Screw	Wrench	Wrench	Insert
	SCP-5		SNS1906	BFTX0511N	TRX20 ^(*)	LH040, LH025	①
	SCP-6		SNS2507	BFTX0615N	TRD25 ^(*)	LH060	②
			SNS2509				③

(*) Note: Wrench (TRX / TRD) for shim clamp screw is not included.

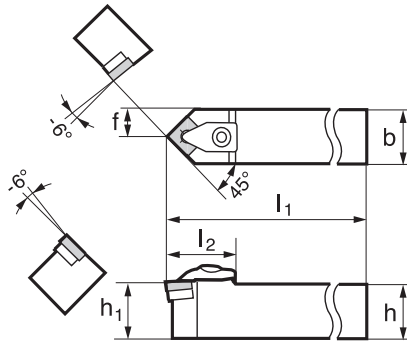
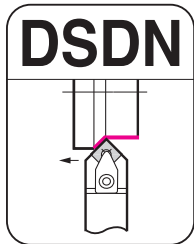

Above figures show right hand tools.

■ Holders

Ordering No.	Stock		Dimensions (mm)					
	R	L	h	h ₁	b	l ₁	l ₂	f
New DSDN N 3232 P19	●	●	32	32	32	170	50	16
New DSDN N 4040 S2507	●	●	40	40	40	250	63	20
New DSDN N 4040 S2509	●	●	40	40	40	250	63	20

■ Inserts

Eg.

N-UZ, N-HU

- ① SNMG 190612 N-UZ
- ② SNMM 250724 N-HU
- ③ SNMM 250924 N-HU

■ Spare Parts

Clamp	Spring	Clamp bolt	Shim	Shim Screw	Wrench	Wrench	Insert
	SCP-5		SNS1906	BFTX0511N	TRX20 ^(*)	LH040, LH025	①
	SCP-6		SNS2507	BFTX0615N	TRD25 ^(*)	LH060	②
			SNS2509				③

(*) Note: Wrench (TRX / TRD) for shim clamp screw is not included.

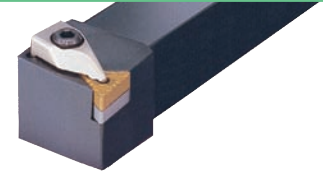

General Turning and Facing

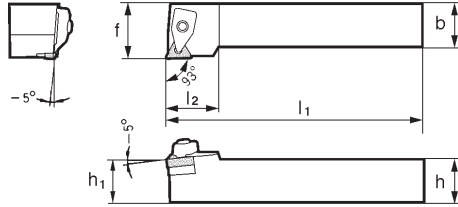
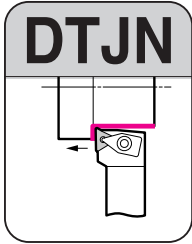

■ Holders

Above figures show right hand tools.

Ordering No.	Stock		Dimensions (mm)					
	R	L	h	h ₁	b	l ₁	l ₂	f
DTJN R/L 2020 K16	●	●	20	20	20	125	31	25
DTJN R/L 2525 M16	●	●	25	25	25	150	31	32

■ Inserts



■ Spare Parts

Clamp	Spring	Clamp bolt	Shim	Shim Screw	Wrench	Wrench	Insert
SCP-1			TNS1604	BFTX0307N	TRX10 ^(*)	LH040	1

^(*) Note: Wrench (TRX) for shim clamp screw is not included.

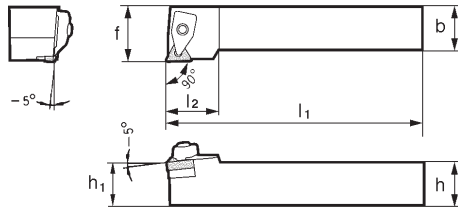

■ Holders

Above figures show right hand tools.

Ordering No.	Stock		Dimensions (mm)					
	R	L	h	h ₁	b	l ₁	l ₂	f
DTGN R/L 2020 K16	○		20	20	20	125	31	25
DTGN R/L 2525 M16	●	●	25	25	25	150	31	32

■ Inserts

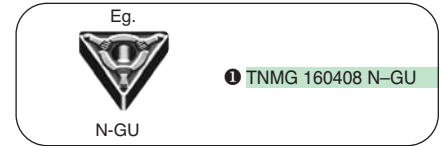

■ Spare Parts

Clamp	Spring	Clamp bolt	Shim	Shim Screw	Wrench	Wrench	Insert
SCP-1			TNS1604	BFTX0307N	TRX10 ^(*)	LH040	1

^(*) Note: Wrench (TRX) for shim clamp screw is not included.

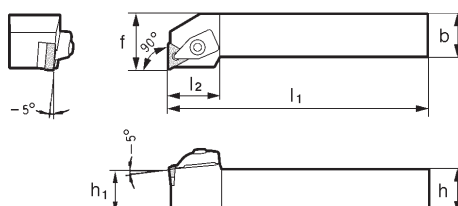
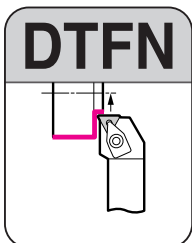

■ Holders

Above figures show right hand tools.

Ordering No.	Stock		Dimensions (mm)					
	R	L	h	h ₁	b	l ₁	l ₂	f
DTFN R/L 2020 K16	○		20	20	20	125	30	25
DTFN R/L 2525 M16	●	●	25	25	25	150	30	32

■ Inserts



■ Spare Parts

Clamp	Spring	Clamp bolt	Shim	Shim Screw	Wrench	Wrench	Insert
SCP-1			TNS1604	BFTX0307N	TRX10 ^(*)	LH040	1

^(*) Note: Wrench (TRX) for shim clamp screw is not included.

External Tool Holders D Type (Double Clamp)

Tool Holders for neg. Inserts VN__

General Turning and Copying

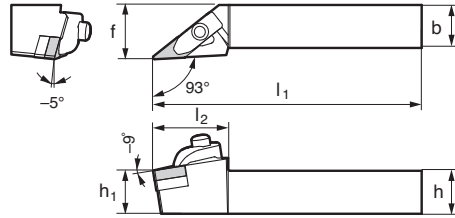
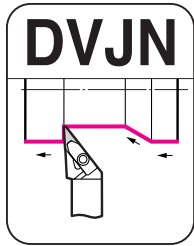

■ Holders

Above figures show right hand tools.

Ordering No.	Stock		Dimensions (mm)					
	R	L	h	h ₁	b	l ₁	l ₂	f
DVJN R/L 2020 K16	●	●	20	20	20	125	35	25
DVJN R/L 2525 M16	●	●	25	25	25	150	35	32

■ Inserts

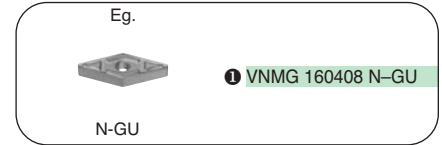

■ Spare Parts

Clamp	Spring	Clamp bolt	Shim	Shim Screw	Wrench	Wrench	Insert
SCP-4			VNS1604	BFTX0307N	TRX10 ^(*)	LH040 LH025	①

(*) Note: Wrench (TRX) for shim clamp screw is not included.

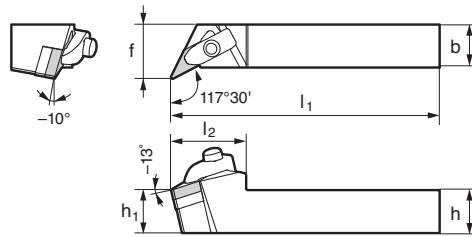
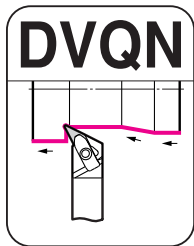

■ Holders

Above figures show right hand tools.

Ordering No.	Stock		Dimensions (mm)					
	R	L	h	h ₁	b	l ₁	l ₂	f
DVQN R/L 2020 K16	●	●	20	20	20	125	35	25
DVQN R/L 2525 M16	●	●	25	25	25	150	35	32

■ Inserts

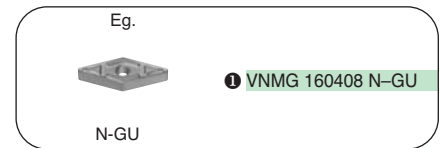

■ Spare Parts

Clamp	Spring	Clamp bolt	Shim	Shim Screw	Wrench	Wrench	Insert
SCP-4			VNS1604	BFTX0307N	TRX10 ^(*)	LH040 LH025	①

(*) Note: Wrench (TRX) for shim clamp screw is not included.

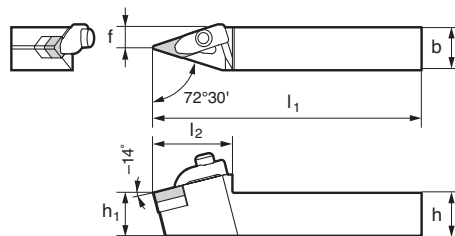
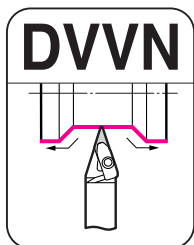

■ Holders

Above figures show right hand tools.

Ordering No.	Stock	Dimensions (mm)					
		h	h ₁	b	l ₁	l ₂	f
DVVN N 2020 K16	●	20	20	20	125	37	10,0
DVVN N 2525 M16	●	25	25	25	150	37	12,5

■ Inserts

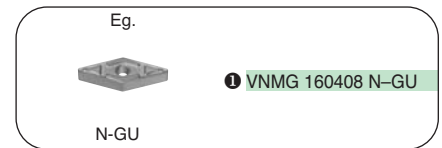

■ Spare Parts

Clamp	Spring	Clamp bolt	Shim	Shim Screw	Wrench	Wrench	Insert
SCP-4			VNS1604	BFTX0307N	TRX10 ^(*)	LH040 LH025	①

(*) Note: Wrench (TRX) for shim clamp screw is not included.

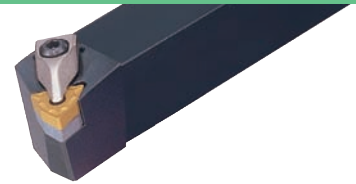

General Turning and Facing

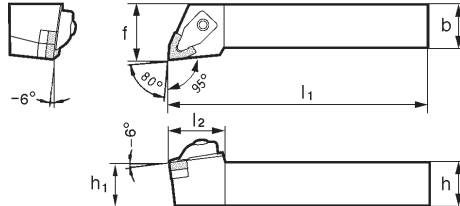
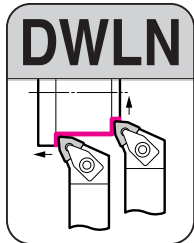

■ Inserts



■ Spare Parts

							Insert
Clamp	Spring	Clamp bolt	Shim	Shim Screw	Wrench	Wrench	
	SCP-2		WNS0804	BFTX0409N	TRX15 ^(*)	LH040 LH025	①

■ Holders

Above figures show right hand tools.

Ordering No.	Stock		Dimensions (mm)						
	R	L	h	h ₁	b	l ₁	l ₂	f	
DWLN R/L 2020 K08	●	●	20	20	20	125	32	25	
DWLN R/L 2525 M08	●	●	25	25	25	150	32	32	

^(*) Note: Wrench (TRX) for shim clamp screw is not included.

External Holders
for neg. Inserts

External Tool Holders P Type (Lever Lock)

Tool Holders for neg. Inserts CN__

General Turning and Facing

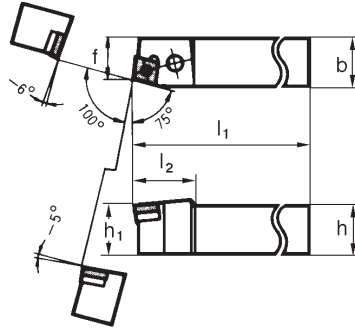
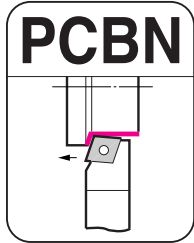

■ Inserts

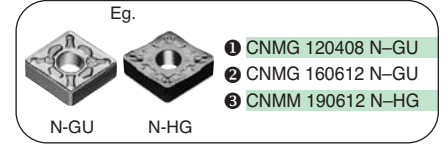

■ Spare Parts

Ordering No.	Stock		Dimensions (mm)						Lever pin	Clamp bolt	Shim	Shim pin	Wrench	Insert
	R	L	h	h ₁	b	l ₁	l ₂	f						
PCBN R/L 2020 K12	●	○	20	20	20	125	27	17	LCL4SD	LCS42BS-SD	LSC42SD	LSP4SD	LH030	①
PCBN R/L 2525 M12	●	●	25	25	25	150	27,7	22						
PCBN R/L 3225 P12	○	●	32	32	25	170	27,7	22	LCL5SD	LCS5B-SD	LSC53SD	LSP5SD	LH030	②
PCBN R/L 2525 M16	○	●	25	25	25	150	31,7	22						
PCBN R/L 3225 P16	○	●	32	32	25	170	31,7	22	LCL6SD	LCS6B-SD	LSC63SD	LSP6SD	LH040	③
PCBN R/L 3232 P19	●	●	32	32	32	170	37,9	27						

Above figures show right hand tools.

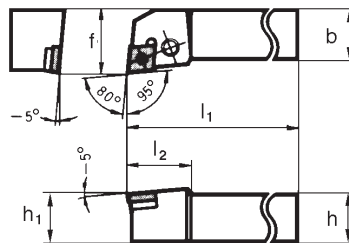
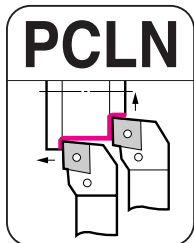

■ Inserts

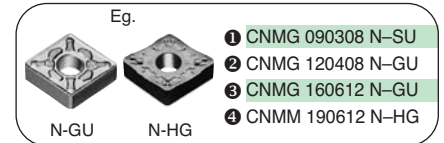

■ Spare Parts

Ordering No.	Stock		Dimensions (mm)						Lever pin	Clamp bolt	Shim	Shim pin	Wrench	Insert
	R	L	h	h ₁	b	l ₁	l ₂	f						
PCLN R/L 1616 H09	●	●	16	16	16	100	25,7	20	LCL3SD	LCS3TB-SD	LSC32SD	LSP3SD-S	LH025	①
PCLN R/L 2020 K09	●	○	20	20	20	125	27	25						
PCLN R/L 2525 M09	○	○	25	25	25	150	27	32	LCL4SD	LCS4CA	LSC42SD	LSP4SD	LH030	②
PCLN R/L 1616 H12	●	●	16	16	16	100	26,1	20						
PCLN R/L 2020 K12	○	○	20	20	20	125	27,4	25	LCL4SD	LCS42BS-SD	LSC42SD	LSP4SD	LH030	②
PCLN R/L 2525 M12	○	○	25	25	25	150	28	32						
PCLN R/L 3225 P12	●	●	32	32	25	170	28	32	LCL5SD	LCS5B-SD	LSC53SD	LSP5SD	LH030	③
PCLN R/L 2525 M16	●	○	25	25	25	150	32,6	32						
PCLN R/L 3225 P16	●	○	32	32	25	170	32,6	32	LCL5SD	LCS5B-SD	LSC53SD	LSP5SD	LH030	③
PCLN R/L 3232 P16	●	●	32	32	32	170	32,6	40						
PCLN R/L 2525 M19	●	○	25	25	25	150	37	32	LCL6SD	LCS6B-SD	LSC63SD	LSP6SD	LH040	④
PCLN R/L 3225 P19	●	○	32	32	32	170	38	32						
PCLN R/L 3232 P19	○	○	32	32	32	170	38	40	LCL6SD	LCS6B-SD	LSC63SD	LSP6SD	LH040	④
PCLN R/L 4040 S19	○	○	40	40	40	250	37,8	50						

Above figures show right hand tools.

■ Holders

External Holders for neg. Inserts



General Turning and Facing

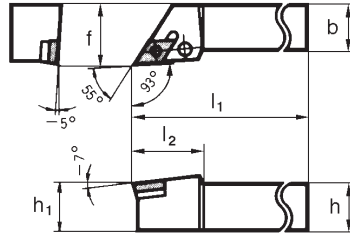
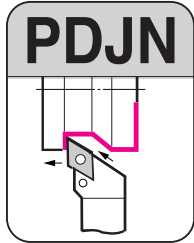

■ Inserts

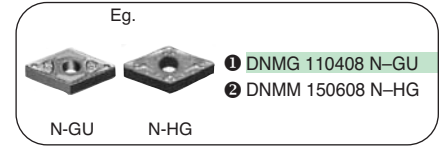

■ Spare Parts

Ordering No.	Stock		Dimensions (mm)							Lever pin	Clamp bolt	Shim	Shim pin	Wrench	Insert
	R	L	h	h ₁	b	l ₁	l ₂	f							
PDJN R/L 1616 H11	●	●	16	16	16	100	30	20							
PDJN R/L 2020 K11	●	●	20	20	20	125	30	25		LCL3D-SD	LCS3TB-SD	LSD32SD	LSP3SD	LH025	①
PDJN R/L 2525 M11	●	●	25	25	25	150	30	32							
PDJN R/L 2020 K15	○	○	20	20	20	125	34,7	25							
PDJN R/L 2525 M15	○	○	25	25	25	150	34,7	32							
PDJN R/L 3225 P15	●	●	32	32	25	170	34,7	32		LCL4D-SD	LCS5DB-SD	LSD42SD	LSP4SD	LH030	②
PDJN R/L 4025 P15	○	○	40	40	25	170	35	28,7							

■ Holders

Above figures show right hand tools.

External Holders
for neg. Inserts

External Tool Holders P Type (Lever Lock)

Tool Holders for neg. Inserts SN__

General Turning and Chamfering

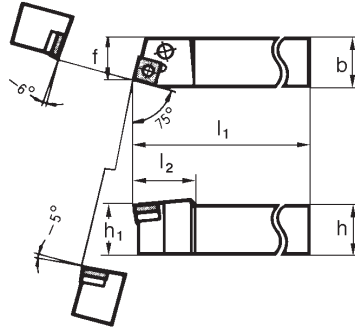
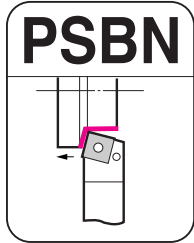

■ Inserts

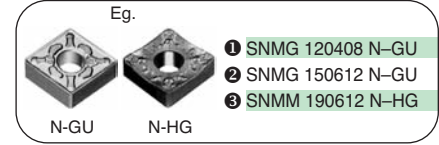

■ Spare Parts

Lever pin	Clamp bolt	Shim	Shim pin	Wrench	Insert
LCL4SD	LCS42BS-SD	LSS42SD	LSP4SD	LH030	1
LCL5SD	LCS5B-SD	LSS53SD	LSP5SD	LH030	2
LCL6SD	LCS6B-SD	LSS63SD	LSP6SD	LH040	3

■ Holders

Above figures show right hand tools.

Ordering No.	Stock		Dimensions (mm)						
	R	L	h	h ₁	b	l ₁	l ₂	f	
PSBN R/L 2020 K12	●	●	20	20	20	125	27,5	17	
PSBN R/L 2525 M12	●	●	25	25	25	150	27,5	22	
PSBN R/L 2525 M15	●	●	25	25	25	150	32	22	
PSBN R/L 3225 P15	●	●	32	32	25	170	32	22	
PSBN R/L 3232 P19	●	●	32	32	32	170	39,2	27	

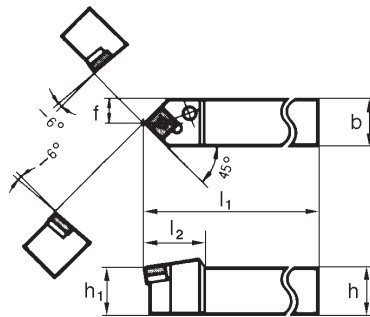
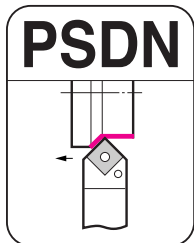

■ Inserts

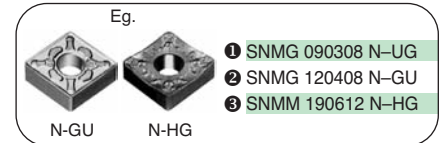

■ Spare Parts

Lever pin	Clamp bolt	Shim	Shim pin	Wrench	Insert
LCL3SD	LCS 3TB-SD	LSS32SD	LSP3SD	LH025	1
LCL4SD	LCS42BS-SD	LSS42SD	LSP4SD	LH030	2
LCL6SD	LCS6B-SD	LSS63SD	LSP6SD	LH040	3

■ Holders

Ordering No.	Stock		Dimensions (mm)						
	R	L	h	h ₁	b	l ₁	l ₂	f	
PSDN N 1616 H09	●		16	16	16	100	21	8,3	
PSDN N 2020 K12	●		20	20	20	125	27,6	10,3	
PSDN N 2525 M12	●		25	25	25	150	27,6	12,8	
PSDN N 3225 P12	●		32	32	25	170	27,6	12,8	
PSDN N 3225 P19	○		32	32	25	170	40,6	13	
PSDN N 3232 P19	●		32	32	32	170	40,6	16,5	



General Turning and Facing

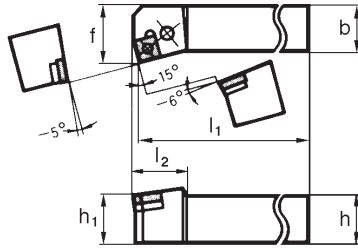
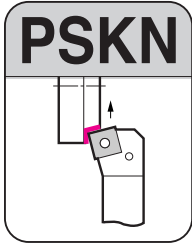

■ Holders

Above figures show right hand tools.

Ordering No.	Stock		Dimensions (mm)						Lever pin	Clamp bolt	Shim	Shim pin	Wrench	Insert	
	R	L	h	h ₁	b	l ₁	l ₂	f							
PSKN R/L 2020 K12	○	○	20	20	20	125	22,7	17							
PSKN R/L 2525 M12	●	●	25	25	25	150	22,7	32	LCL4SD	LCS42BS-SD	LSS42SD	LSP4SD	LH030	①	
PSKN R/L 3225 P12	○	○	32	32	25	170	22,7	32							
PSKN R/L 2525 M15	○	●	25	25	25	150	32	32							
PSKN R/L 3225 P15	○	●	32	32	25	170	32	32	LCL5SD	LCS5B-SD	LSS53SD	LSP5SD	LH030	②	
PSKN R/L 3232 P15	○	○	32	32	32	170	32	40							
PSKN R/L 3232 P19	○	○	32	32	32	170	33,7	40	LCL6SD	LCS6B-SD	LSS63SD	LSP6SD	LH040	③	

■ Inserts

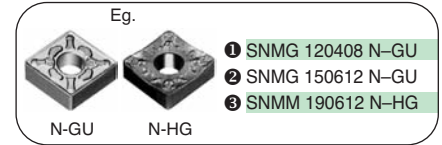

■ Spare Parts

Lever pin	Clamp bolt	Shim	Shim pin	Wrench	Insert

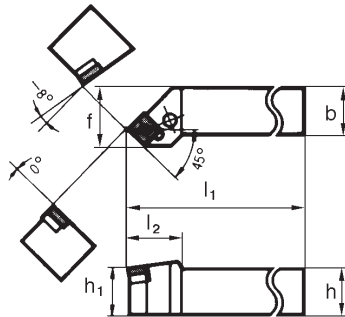
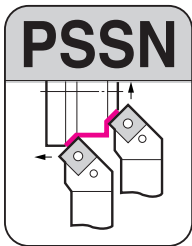

■ Holders

Above figures show right hand tools.

Ordering No.	Stock		Dimensions (mm)						Lever pin	Clamp bolt	Shim	Shim pin	Wrench	Insert
	R	L	h	h ₁	b	l ₁	l ₂	f						
PSSN R/L 2020 K12	●	●	20	20	20	125	29,3	25						
PSSN R/L 2525 M12	●	●	25	25	25	150	29,3	32	LCL4SD	LCS42BS-SD	LSS42SD	LSP4SD	LH030	①
PSSN R/L 3225 P12	●	○	32	32	25	170	29,3	32						
PSSN R/L 2525 M15	●	●	25	25	25	150	32	32						
PSSN R/L 3225 P15	○	○	32	32	25	170	32	32	LCL5SD	LCS5B-SD	LSS53SD	LSP5SD	LH030	②
PSSN R/L 3232 P15	●	○	32	32	32	170	32	40						
PSSN R/L 3232 P19	●	●	32	32	32	170	40,2	40	LCL6SD	LCS6B-SD	LSS63SD	LSP6SD	LH040	③

■ Inserts

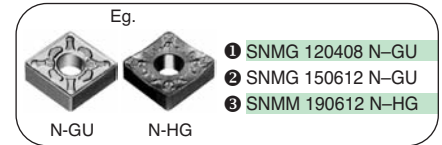

■ Spare Parts

Lever pin	Clamp bolt	Shim	Shim pin	Wrench	Insert

External Tool Holders P Type (Lever Lock)

Tool Holders for neg. Inserts TN__

General Turning and Facing

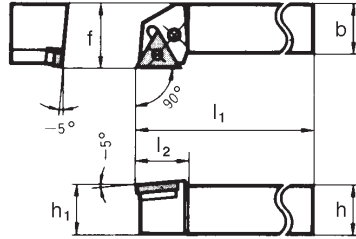
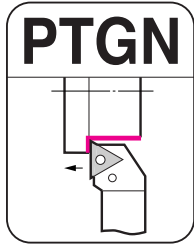
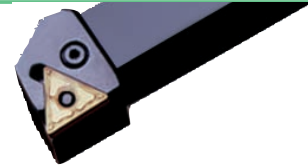

Inserts



Spare Parts

Ordering No.	Stock	Dimensions (mm)							Lever pin	Clamp bolt	Shim	Shim pin	Wrench	Insert
	R L	h	h ₁	b	l ₁	l ₂	f							
PTGN R/L 1616 H16	● ●	16	16	16	100	20	20							
PTGN R/L 2020 K16	● ●	20	20	20	125	20	25		LCL3SD	LCS3TB-SD	LST317SD	LSP3SD	LH025	1
PTGN R/L 2525 M16	● ●	25	25	25	150	22,2	32							
PTGN R/L 2525 M22	● ●	25	25	25	150	28,7	32							
PTGN R/L 3225 P22	● ●	32	32	25	170	28,7	32		LCL4SD	LCS42BS-SD	LST42SD	LSP4SD	LH030	2
PTGN R/L 3232 P22	● ●	32	32	32	170	28,7	32							

Holders

Above figures show right hand tools.

Ordering No.	Stock	Dimensions (mm)							Lever pin	Clamp bolt	Shim	Shim pin	Wrench	Insert
	R L	h	h ₁	b	l ₁	l ₂	f							
PTGN R/L 1616 H16	● ●	16	16	16	100	20	20							
PTGN R/L 2020 K16	● ●	20	20	20	125	20	25		LCL3SD	LCS3TB-SD	LST317SD	LSP3SD	LH025	1
PTGN R/L 2525 M16	● ●	25	25	25	150	22,2	32							
PTGN R/L 2525 M22	● ●	25	25	25	150	28,7	32							
PTGN R/L 3225 P22	● ●	32	32	25	170	28,7	32		LCL4SD	LCS42BS-SD	LST42SD	LSP4SD	LH030	2
PTGN R/L 3232 P22	● ●	32	32	32	170	28,7	32							

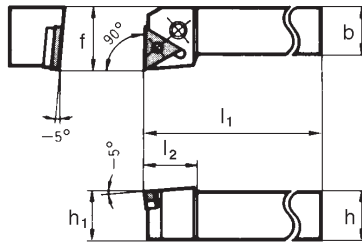
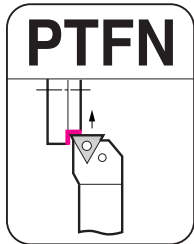

Inserts

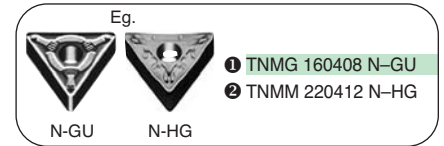

Spare Parts

Ordering No.	Stock	Dimensions (mm)							Lever pin	Clamp bolt	Shim	Shim pin	Wrench	Insert
	R L	h	h ₁	b	l ₁	l ₂	f							
PTFN R/L 1616 H16	● ●	16	16	16	100	19,7	20							
PTFN R/L 2020 K16	● ●	20	20	20	125	20,2	25		LCL3SD	LCS3TB-SD	LST317SD	LSP3SD	LH025	1
PTFN R/L 2525 M16	● ●	25	25	25	150	20,2	32							
PTFN R/L 2525 M22	● ●	25	25	25	150	25,2	32							
PTFN R/L 3225 P22	● ●	32	32	25	170	25,2	32		LCL4SD	LCS42BS-SD	LST42SD	LSP4SD	LH030	2

Holders

Above figures show right hand tools.

Ordering No.	Stock	Dimensions (mm)							Lever pin	Clamp bolt	Shim	Shim pin	Wrench	Insert
	R L	h	h ₁	b	l ₁	l ₂	f							
PTFN R/L 1616 H16	● ●	16	16	16	100	19,7	20							
PTFN R/L 2020 K16	● ●	20	20	20	125	20,2	25		LCL3SD	LCS3TB-SD	LST317SD	LSP3SD	LH025	1
PTFN R/L 2525 M16	● ●	25	25	25	150	20,2	32							
PTFN R/L 2525 M22	● ●	25	25	25	150	25,2	32							
PTFN R/L 3225 P22	● ●	32	32	25	170	25,2	32		LCL4SD	LCS42BS-SD	LST42SD	LSP4SD	LH030	2

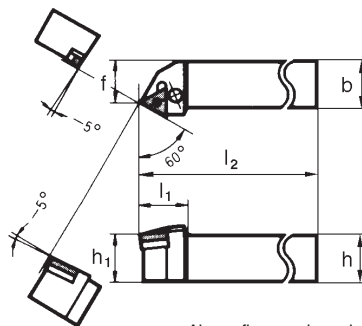
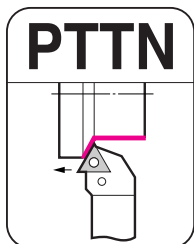

Inserts

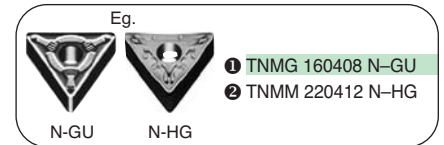

Spare Parts

Ordering No.	Stock	Dimensions (mm)							Lever pin	Clamp bolt	Shim	Shim pin	Wrench	Insert
	R L	h	h ₁	b	l ₁	l ₂	f							
PTTN R/L 2020 K16	○ ○	20	20	20	125	25,9	17							
PTTN R/L 2525 M16	● ○	25	25	25	150	25,9	22		LCL3SD	LCS3TB-SD	LST317SD	LSP3SD	LH025	1
PTTN R/L 2525 M22	○ ○	25	25	25	150	31,9	22							
PTTN R/L 3225 P22	○ ●	32	32	25	170	31,9	22		LCL4SD	LCS42BS-SD	LST42SD	LSP4SD	LH030	2

Holders

Above figures show right hand tools.

Ordering No.	Stock	Dimensions (mm)							Lever pin	Clamp bolt	Shim	Shim pin	Wrench	Insert
	R L	h	h ₁	b	l ₁	l ₂	f							
PTTN R/L 2020 K16	○ ○	20	20	20	125	25,9	17							
PTTN R/L 2525 M16	● ○	25	25	25	150	25,9	22		LCL3SD	LCS3TB-SD	LST317SD	LSP3SD	LH025	1
PTTN R/L 2525 M22	○ ○	25	25	25	150	31,9	22							
PTTN R/L 3225 P22	○ ●	32	32	25	170	31,9	22		LCL4SD	LCS42BS-SD	LST42SD	LSP4SD	LH030	2



General Turning and Copying

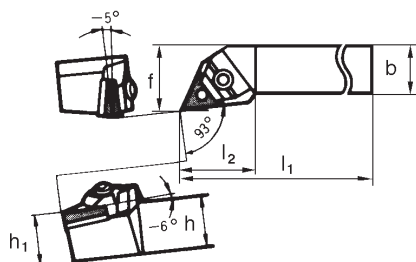
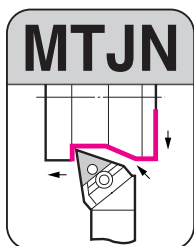

■ Holders

Above figures show right hand tools.

Ordering No.	Stock		Dimensions (mm)						Wedge	Shim pin	Shim	Clamp bold	Nut	Ring	Wrench	Insert
	R	L	h	h ₁	b	l ₁	l ₂	f								
MTJN R/L 2020-33 (K16)	●	●	20	20	20	125	37	25	MMW30	MP317	STW323	BHA0525	CPM32N	ER04	LH030	①
MTJN R/L 2525-33 (M16)	●	●	25	25	25	150	37	32	MMW30	MP320	STW323	BHA0525	CPM32N	ER04	LH030	①
MTJN R/L 2525-43 (M22)	●	●	25	25	25	150	37	32	MMW40	MP320	STW434	BHA0625	CPM43N	ER05	LH030	②
MTJN R/L 3225-43 (P22)	○	○	32	32	25	170	37	32	MMW40	MP320	STW434	BHA0625	CPM43N	ER05	LH030	②
MTJN R/L V-43 (D22)			20	20	25	60	37	30	MMW40	MP416	STW434	BHA0625	CPM43N	ER05	LH040	②

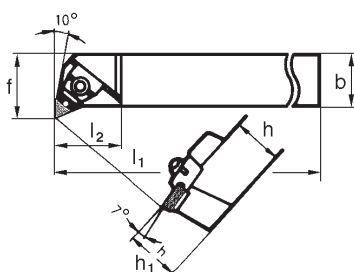
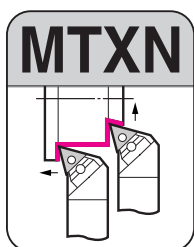

■ Holders

Above figures show right hand tools.

Ordering No.	Stock		Dimensions (mm)						Wedge	Shim pin	Shim	Clamp bold	Nut	Ring	Wrench	Insert
	R	L	h	h ₁	b	l ₁	l ₂	f								
MTXN R/L 2020-33 (K16)	○	○	20	20	20	125	32	25	MMW30	MP317	STW323	BHA0525	CPM32N	ER04	LH030	①
MTXN R/L 2525-33 (M16)	○	○	25	25	25	150	32	32	MMW30	MP320	STW323	BHA0525	CPM32N	ER04	LH030	①
MTXN R/L 2525-43 (M22)			25	25	25	150	38	32	MMW40	MP320	STW434	BHA0625	CPM43N	ER05	LH030, 040	②

■ Inserts

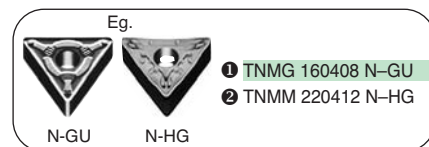

■ Spare Parts

							Insert
--	--	--	--	--	--	--	--------

■ Inserts

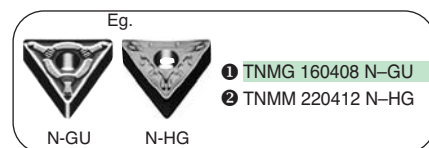

■ Spare Parts

							Insert
--	--	--	--	--	--	--	--------

External Holders
for neg. Inserts

External Tool Holders M Type (Wedge Clamp)

Tool Holders for neg. Inserts WN__

General Turning and Facing

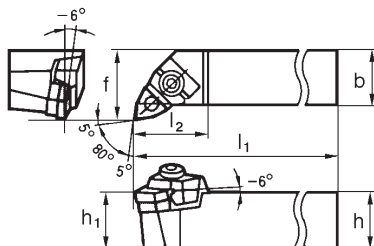
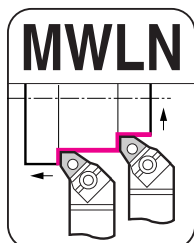
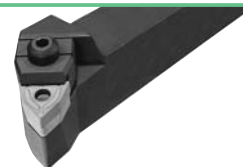

■ Inserts

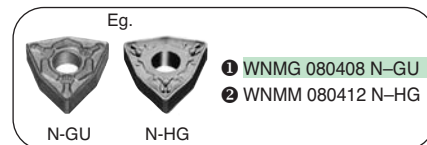

■ Spare Parts

Wedge	Shim pin	Shim	Clamp bolt	Nut	Ring	Wrench	Insert
MWW40	MP416 MP420	SWW433	BHA0625	CPM43S CPM43N	ER05	LH030 LH040	1, 2
MWW50	MP531 MP534	SWW544	BHA0834	CPM54N	ER07	LH040 LH050	

■ Holders

Above figures show right hand tools.

Ordering No.	Stock		Dimensions (mm)						
	R	L	h	h ₁	b	l ₁	l ₂	f	
MWLN R/L 2020-43 (K08)			20	20	20	125	32	25	
MWLN R/L 2525-43 (M08)	○	○	25	25	25	150	32	32	
MWLN R/L 3225-43 (P08)	○	○	32	32	25	170	32	32	
MWLN R/L 2525-54 (M10)			25	25	25	150	37	32	
MWLN R/L 3225-54 (P10)			32	32	25	170	37	32	

P-Type Lever-Lock Holders

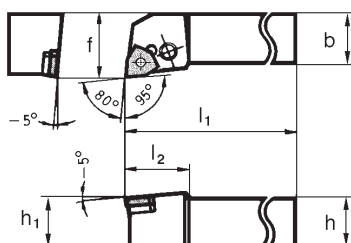
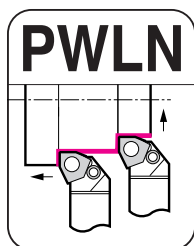

■ Inserts

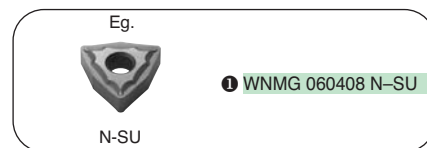

■ Spare Parts

Lever pin	Clamp bolt	Shim	Shim pin	Wrench	Insert
LCL3SD	LCS3TB-SD	LSW317	LSP3SD	LH025	1

■ Holders

Above figures show right hand tools.

Ordering No.	Stock		Dimensions (mm)						
	R	L	h	h ₁	b	l ₁	l ₂	f	
PWLN R/L 2020 K06 (PWLN R/L 2020 -33)	○	○	20	20	20	125	27	25	
PWLN R/L 2525 M06 (PWLN R/L 2525 -33)	○	○	25	25	25	150	27	32	

External Tool Holders for Solid SUMIBORON

C Type Top Clamp Holders

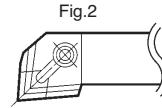
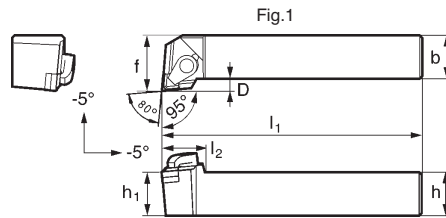
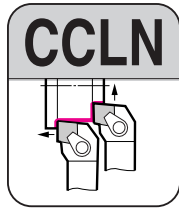

Inserts



■ Holders

Above figures show right hand tools.

Ordering No.	Stock		Dimensions (mm)							Fig.	Clamp	Insert protector	Clamp bolt	Shim	Shim pin	Wrench	Insert
	R	L	h=h ₁	b	l ₁	l ₂	f	D									
CCLN R/L 2525 M09	●		25	25	150	25	32	7	1	CCM8UL	CBC0903	WB8-22T	SCN0903	SPP3	LT27		①
CCLN R/L 2525 M12-03	●		25	25	150	30	32	7	1	CCM8UL	CBC4	WB8-22T	SCND433	SPP3	LT27		②
CCLN R/L 2525 M12-04	●		25	25	150	30	32	7	2	CCM8-LONG	CBC4	WB8-30	SCND433	SPP3	LH040		③

(FCLN R/L 2525-43)

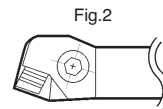
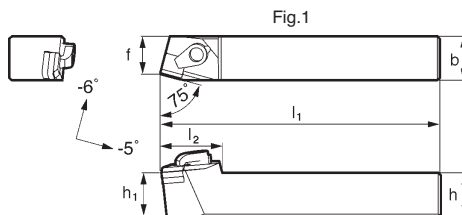
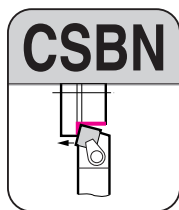

■ Inserts

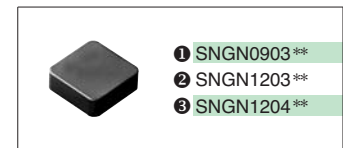

■ Holders

Above figures show right hand tools.

Ordering No.	Stock		Dimensions (mm)							Fig.	Clamp	Insert protector	Clamp bolt	Shim	Shim pin	Spring	Wrench	Insert
	R	L	h=h ₁	b	l ₁	l ₂	f	D										
CSBN R/L 2525 N09	●		25	25	160	30	21,5	-	1	CCM8UL	CBS13	WB8-22T	SSN0903	-	-	-	LH040	①
CSBN R/L 2525 N12-03	●		25	25	160	35	21,5	-	1	CCM8UL	CBS14	WB8-22T	SSND423	-	-	-	LH040	②

CSBN R/L 2525 N12-04	●		25	25	160	33	21,5	-	2	DC-R/L 1	CBD 4 R/L	BH 0830 R/L	SSND423	SPP3	DSP5	LH040	③
-----------------------------	---	--	----	----	-----	----	------	---	---	----------	-----------	-------------	---------	------	------	-------	---

(FN11 R-44A)

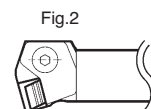
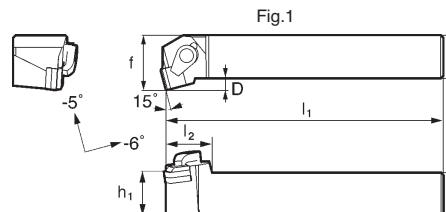
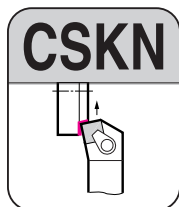

■ Inserts

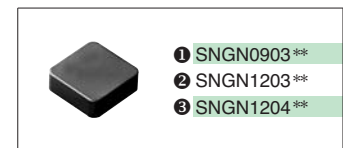

■ Holders

Above figures show right hand tools.

Ordering No.	Stock		Dimensions (mm)							Fig.	Clamp	Insert protector	Clamp bolt	Shim	Shim pin	Spring	Wrench	Insert
	R	L	h=h ₁	b	l ₁	l ₂	f	D										
CSKN R/L 2525 N09	●		25	25	160	25	32	7	1	CCM8UL	CBS13	WB8-22T	SSN0903	-	-	-	LH040	①
CSKN R/L 2525 N12-03	●		25	25	160	25	32	7	1	CCM8UL	CBS14	WB8-22T	SSND423	-	-	-	LH040	②

CSKN R/L 2525 N12-04	●		25	25	160	21	32	7	2	DC-L/R 1	CBD 4 L/R	BH 0830 L/R	SSND423	SPP3	DSP5	LH040	③
-----------------------------	---	--	----	----	-----	----	----	---	---	----------	-----------	-------------	---------	------	------	-------	---

(FN15 R/L-44A)

● = Euro stock

Packing unit and ordering example; 1 pce CCLNR 2525 M09

(R: right handed)

External Holders for neg. Inserts

External Tool Holders for Solid SUMIBORON

C Type Top Clamp Holders

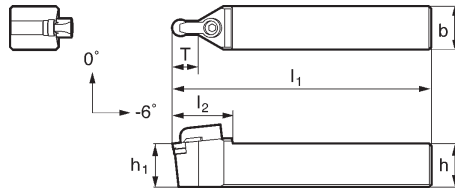
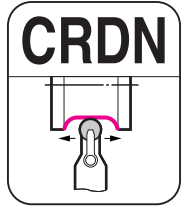

■ Inserts



■ Holders

Ordering No.	Stock	Dimensions (mm)						
		h	h ₁	b	l ₁	l ₂	f	T
CRDNN 2525 M09	●	25	25	25	150	35	-	15
CRDNN 2525 M12-03	●	25	25	25	150	35	-	20
CRDNN 2525 M12-04	●	25	25	25	150	35	-	20

■ Spare Parts

Clamp	Double screw	Shim	Shim pin	Wrench	Insert
CCM8-LONG	WB8-22T	SRND32	SPP3	LT27	1
		SRND42			2
					3

External Holders for neg. Inserts

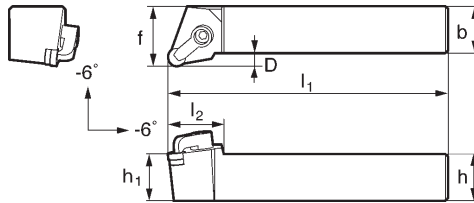
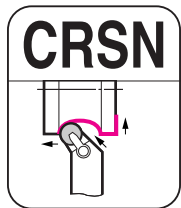

■ Inserts



■ Holders

Above figures show right hand tools.

Ordering No.	Stock		Dimensions (mm)						
	R	L	h	h ₁	b	l ₁	l ₂	f	D
CRSN R/L 2525 M09	●	●	25	25	25	150	30	32	7
CRSN R/L 2525 M12-03	●	●	25	25	25	150	30	32	7
CRSN R/L 2525 M12-04	●	●	25	25	25	150	30	32	7

■ Spare Parts

Clamp	Double screw	Shim	Shim pin	Wrench	Insert
CCM8-LONG	WB8-22T	SRND32	SPP3	LT27	1
		SRND42			2
					3

X-Type Dimple Lock Holders

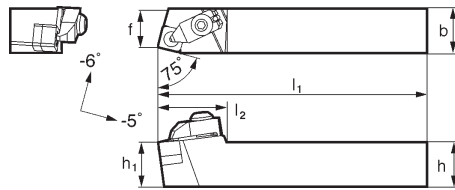
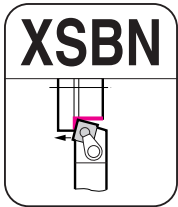

■ Inserts

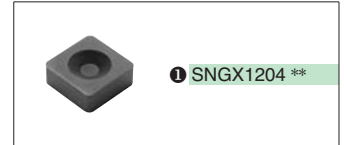

■ Spare Parts

■ Holders

Above figures show right hand tools.

Ordering No.	Stock		Dimensions (mm)							Clamp	Clamp bolt	Shim	Shim pin	Spring	Wrench	Insert
	R	L	h	h ₁	b	l ₁	l ₂	f	D							
XSBN R/L 2525 N12	●		25	25	25	160	38	21,5	7	DSLX8	BH0825	SSND433	SPP3	GSP10	LH050	1

							Insert

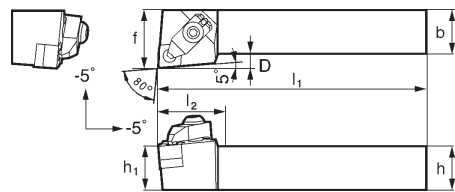
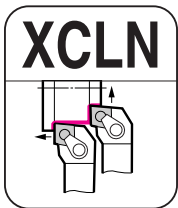

■ Inserts



■ Spare Parts

■ Holders

Above figures show right hand tools.

Ordering No.	Stock		Dimensions (mm)							Clamp	Clamp bolt	Shim	Shim pin	Spring	Wrench	Insert
	R	L	h	h ₁	b	l ₁	l ₂	f	D							
XCLN R/L 2525 M12	●		25	25	25	150	33	32	7	DSLX8	BH0825	SCND433	SPP3	GSP10	LH050	1

							Insert

External Mini Holders

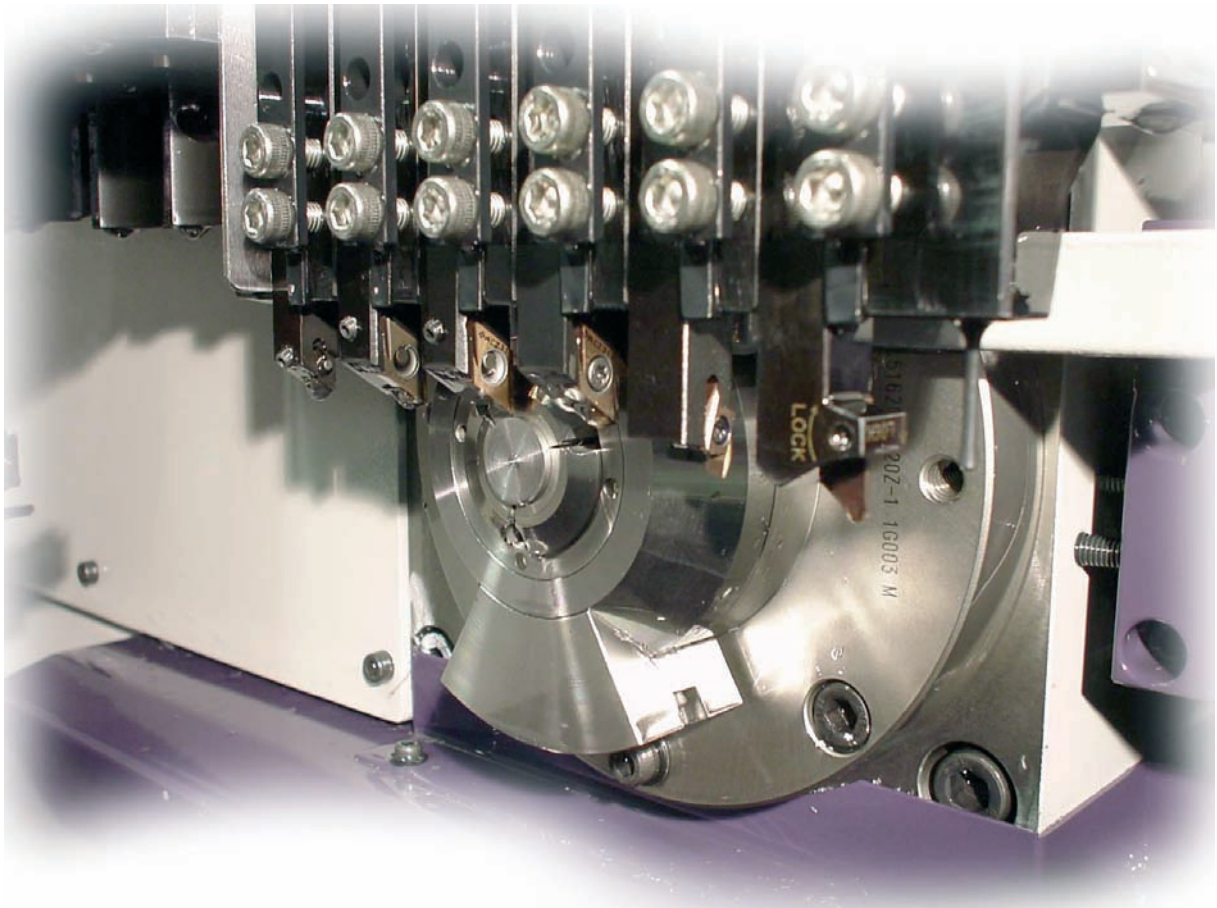

External Holders
for pos. Inserts

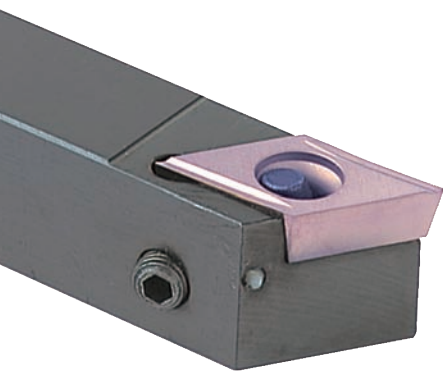

PDJCR type
lever lock holder

Wear-resistant tool materials;
T1200A (Cermet) and
AC530U (2000 layers
coated carbide grade)

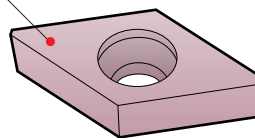

Sharp cutting edge
($r = 0,03$
0,1 and 0,2 mm)

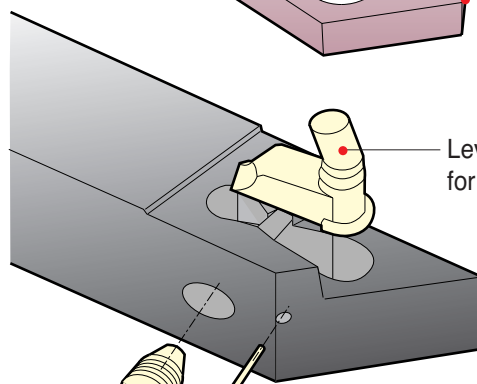

Lever lock clamping
for 7° positive inserts

Easy access
side locking screw

For Mini Tool Holders 7° positive Inserts

Wear resistance of ZX coated grade AC530U

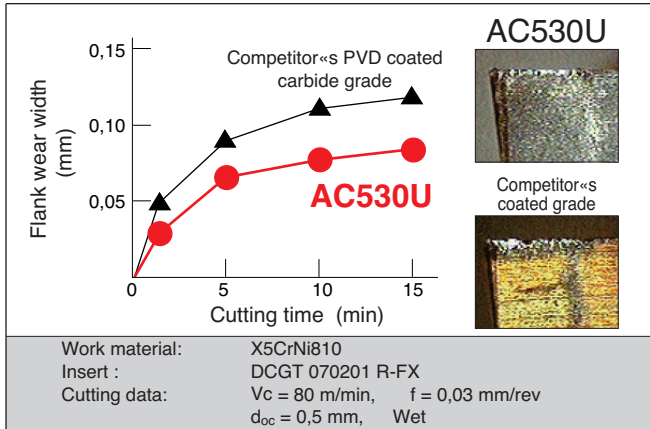

Wear resistance of tough ZX coated Cermet

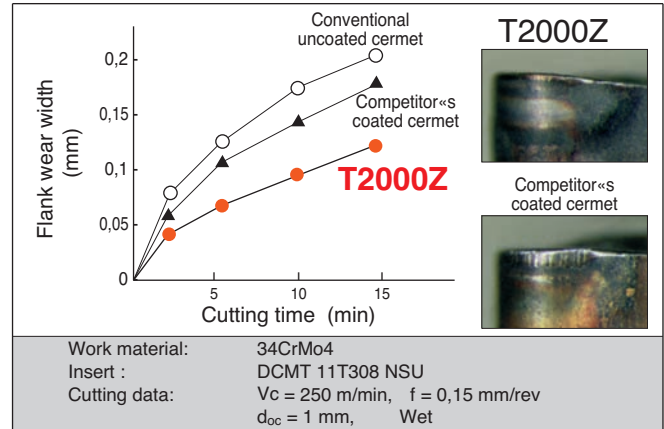

High performance of coated CBN grades BNC160 and BNC200



TiAlN coated CBN grade **BNC200** for high speed continuous to medium interrupted cutting

TiN coated CBN grade BNC160 for high precision hard turning

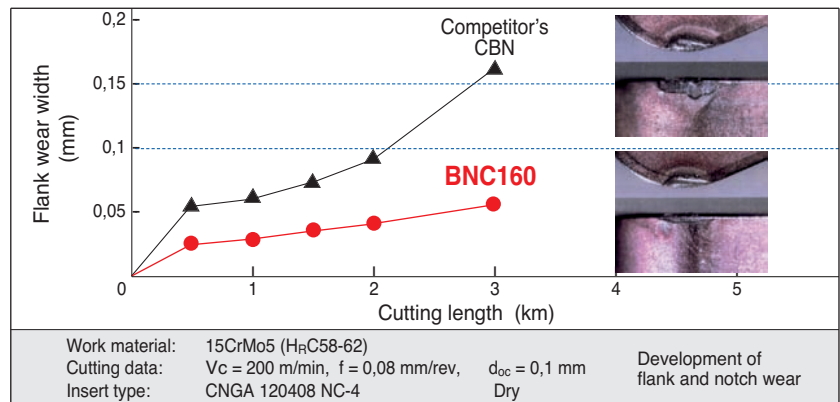

Recommended grades

Cutting material	Application	
	Finishing	Roughing
Coated carbide	AC530U	
	AC820P	
		AC830P
Uncoated carbide		H1
Coated Cermet	T2000Z	
		T3000Z
Uncoated Cermet	T1200A	
Coated CBN	BNC100	
	BNC160	
		BNC200
		BNC300
Uncoated CBN	BNX20	
	BN250	
	BN700	
PCD SUMIDIA	DA2200	

Recommended cutting conditions

Workpiece material	Sumitomo grade	Cutting speed	
		V_c (m/min)	Feed rate f (mm/rev)
General steel	AC530U	50 - 180	0,05 - 0,2
	AC820P	100 - 250	0,05 - 0,2
	AC830P	80 - 200	0,05 - 0,2
	T2000Z	100 - 300	0,05 - 0,2
	T1200A	100 - 250	0,05 - 0,2
Stainless steel	AC530U	40 - 120	0,02 - 0,2
Hardened steel	BNC100	150 - 300	0,03 - 0,2
	BNC160	150 - 220	0,03 - 0,2
	BNC200	100 - 200	0,05 - 0,2
	BNC300	50 - 150	0,02 - 0,2
Exotic materials	BN700 (BN600)	50 - 170	0,02 - 0,15
Non-ferrous metals	DA2200	400 - 3000	0,02 - 0,15
	H1	200 - 2500	0,05 - 0,5

External Mini Tool Holders SBT Type

Special Mini Holders for Back Facing

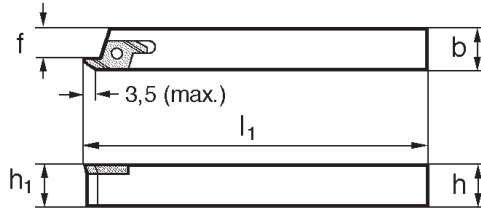
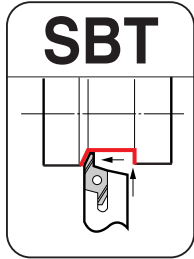

■ Spare Parts

Ordering No.	Stock	Dimensions (mm)					Screw	Wrench	Insert
h	h ₁	b	l ₁	f					
SBT 35 R 1010	●	10	10	10	120	7,5			
SBT 35 R 1212	●	12	12	12	120	9,5	BFTX0307N	TRX10	BTR 35...
SBT 35 R 1616	●	16	16	16	120	13,5			

■ Holders

Above figures show right hand tools.

External Holders for pos. Inserts

■ INSERTS

Coated carbide

Coated Cermet

BTR	Ordering No.	Stock		Dimensions (mm)			d	s	r	
		ACZ310	T1200A							
	BTR 3505	●	●				6,8	3,8	0,05	
	BTR 3515	●	●						0,15	

Sharp cutting edge with 15° rake angle

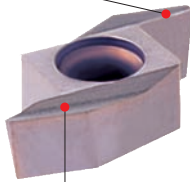

Wide groove breaker for smooth chip evacuation

● Surface roughness comparison

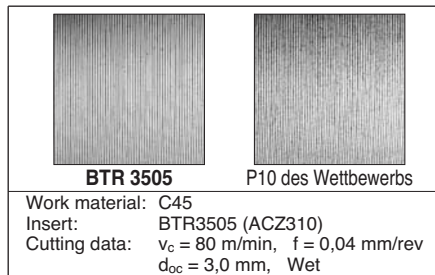

■ Recommended cutting data (SBT type)

Work material	Tooling	v _c (m/min)	f (mm/rev)
General steel	Grooving	50 ~ 150	0,02 ~ 0,05
	Back facing		0,02 ~ 0,10
Free-cutting steel	Grooving	50 ~ 150	0,02 ~ 0,10
	Back facing		0,02 ~ 0,15
Stainless steel	Grooving	50 ~ 150	0,02 ~ 0,04
	Back facing		0,02 ~ 0,06

(Coated carbide & Coated Cermet)

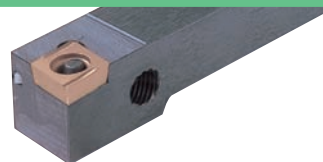

P Type Lever Lock Holders

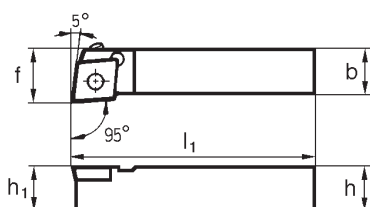
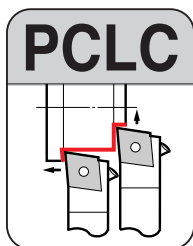

■ Inserts

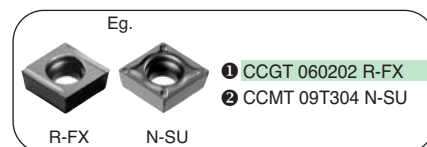

■ Spare Parts

■ Holders

Above figures show right hand tools.

Ordering No.	Stock		Dimensions (mm)					Lever pin	Clamp screw	Side pin	Wrench	Insert
	R	L	h	h ₁	b	l ₁	f					
PCLC R/L 0810 K06	○	○	8	8	10	125	10,5	LCL 06	BTT 0407	LP 07	TH 020	①
PCLC R/L 1010 K06	●	○	10	10	10	125	10,5	LCL 09		LP 06		
PCLC R/L 1212 M09	●	●	12	12	12	150	12,5					
PCLC R/L 1616 M09	●		16	16	16	150	16,5					

S Type Screw Lock Holders

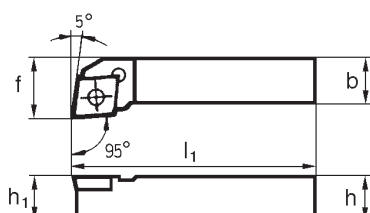
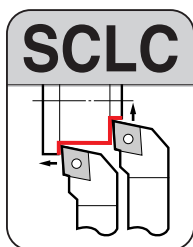

■ Inserts

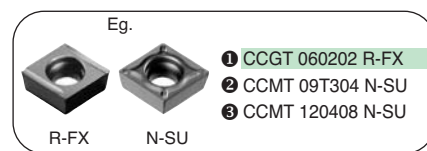

■ Spare Parts

■ Holders

Above figures show right hand tools.

Ordering No.	Stock		Dimensions (mm)					Screw	Wrench	Insert		
	R	L	h	h ₁	b	l ₁	f					
SCLC R/L 0808 D06	●	●	8	8	8	60	10	BFTX02506N	TRX08	①		
SCLC R/L 1010 E06	●	●	10	10	10	70	12					
SCLC R/L 1212 F09	●	●	12	12	12	80	16	BFTX0409N	TRX15	②		
SCLC R/L 1616 H09	●	●	16	16	16	100	20					
SCLC R/L 2020 H09	●	○	20	20	20	100	25					
SCLC R/L 2020 K09	●	●	20	20	20	125	25	BFTX0511N	TRX20	③		
SCLC R/L 2020 K12	●	●	20	20	20	125	25					
SCLC R/L 2525 M12	●	●	20	25	25	150	32					

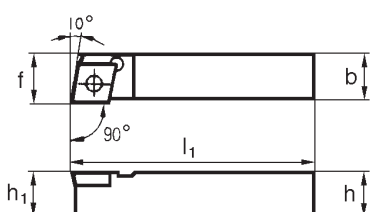
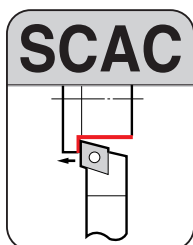

■ Inserts

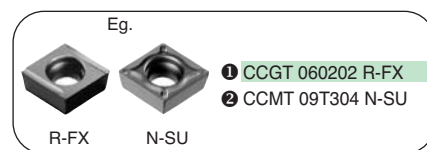

■ Spare Parts

■ Holders

Above figures show right hand tools.

Ordering No.	Stock		Dimensions (mm)					Screw	Wrench	Insert
	R	L	h	h ₁	b	l ₁	f			
SCAC R/L 0808 D06	●	●	8	8	8	60	8,5	BFTX02506N	TRX08	①
SCAC R/L 1010 E06	●	●	10	10	10	70	10,5			
SCAC R/L 1212 F09	●	●	12	12	12	80	12,5	BFTX0409N	TRX15	②

External Mini Tool Holders PD/SD Type

Mini Holders for 7° DC__ pos. Inserts



P Type Lever Lock Holders

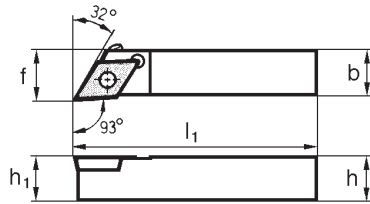
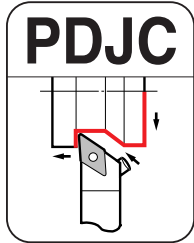

■ Inserts

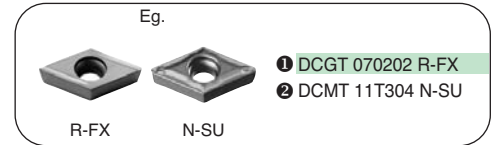

■ Spare Parts

■ Holders

Above figures show right hand tools.

Ordering No.	Stock		Dimensions (mm)					Lever pin	Clamp screw	Side pin	Wrench	Insert
	R	L	h	h ₁	b	l ₁	f					
PDJC R/L 0810 K07	●	○	8	8	10	125	10,5	LCL 06	BTT 0407	LP 04	TH 020	1
PDJC R/L 1010 K07	●	●	10	10	10	125	10,5	LCL 09		LP 07		2
PDJC R/L 1212 M11	●	●	12	12	12	150	12,5		BTT 0411	LP 07	TH 020	2
PDJC R/L 1616 M11	●	○	16	16	16	150	16,5					

External Holders for pos. Inserts

S Type Screw Lock Holders

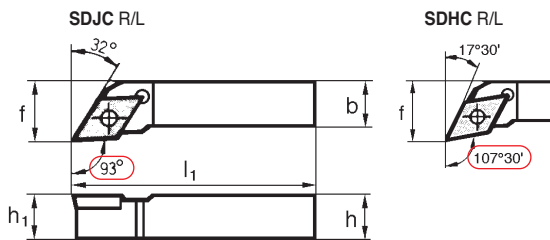
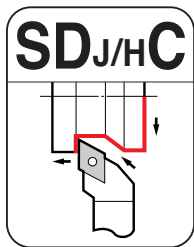

■ Inserts

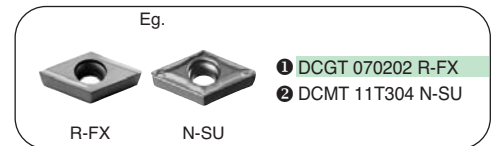

■ Spare Parts

■ Holders

Above figures show right hand tools.

Ordering No.	Stock		Dimensions (mm)					Screw	Wrench	Insert
	R	L	h	h ₁	b	l ₁	f			
SDJC R/L 0808 D07	●	●	8	8	8	60	10	BFTX02506N	TRX08	1
SDJC R/L 1010 E07	●	●	10	10	10	70	12			
SDJC R/L 1212 F07	●	●	12	12	12	80	16			
SDJC R/L 1616 H07	●	●	16	16	16	100	20			
SDJC R/L 2020 K07	●	●	20	20	20	125	25	BFTX0409N	TRX15	2
SDJC R/L 1212 F11	●	●	12	12	12	80	16			
SDJC R/L 1616 H11	●	●	16	16	16	100	20			
SDJC R/L 2020 K11	●	●	20	20	20	125	25			
SDJC R/L 2525 M11	●	●	25	25	25	150	32			
SDHC R/L 1616 H11	●	●	16	16	16	100	20	BFTX0409N	TRX15	2
SDHC R/L 2020 K11	●	●	20	20	20	125	25			
SDHC R/L 2525 M11	●	●	25	25	25	150	32			



S Type Screw Lock Holders

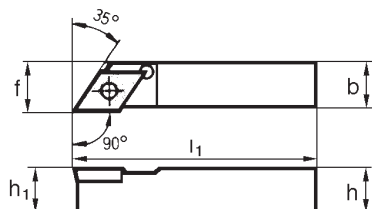
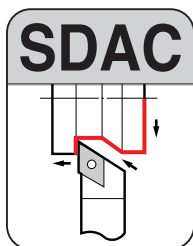

■ Holders

Above figures show right hand tools.

Ordering No.	Stock		Dimensions (mm)					Screw	Wrench	Insert
	R	L	h	h ₁	b	l ₁	f			
SDAC R/L 0808 D07	○	●	8	8	8	60	8,5	BFTX02506N	TRX08	①
SDAC R/L 1010 E07	●	●	10	10	10	70	10,5			
SDAC R/L 1212 F11	●	●	12	12	12	80	12,5	BFTX0409N	TRX15	②

■ Inserts

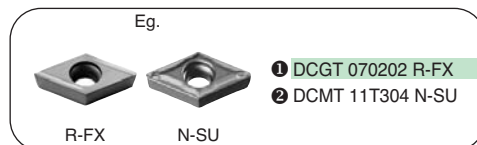

■ Spare Parts

Screw	Wrench	Insert
BFTX02506N	TRX08	①
BFTX0409N	TRX15	②

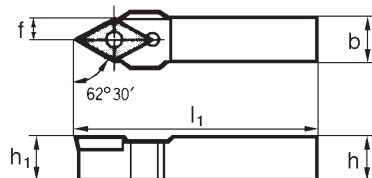
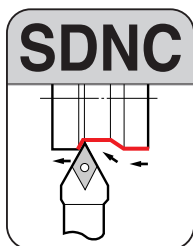

■ Holders

Ordering No.	Stock	Dimensions (mm)					Screw	Wrench	Insert
		h	h ₁	b	l ₁	f			
SDNCN 0808 D07	●	8	8	8	60	4,2	BFTX02506N	TRX08	①
SDNCN 1010 E07	●	10	10	10	70	5,2			
SDNCN 1212 F07	●	12	12	12	80	6,2			
SDNCN 1616 H07	●	16	16	16	100	8,2			
SDNCN 2020 K07	●	20	20	20	125	10,2	BFTX0409N	TRX15	②
SDNCN 1212 F11	●	12	12	12	80	6,5			
SDNCN 1616 H11	●	16	16	16	100	8,5			
SDNCN 2020 K11	●	20	20	20	125	10,5			
SDNCN 2525 M11	●	25	25	25	150	13			

■ Inserts

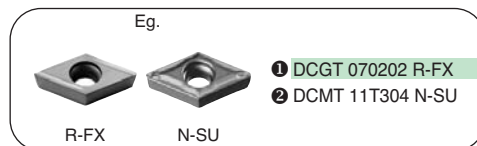

■ Spare Parts

Screw	Wrench	Insert
BFTX02506N	TRX08	①
BFTX0409N	TRX15	②

External Tool Holders PR Type

External Holders for 7° RC__ pos. Inserts

P Type Lever Lock Holders

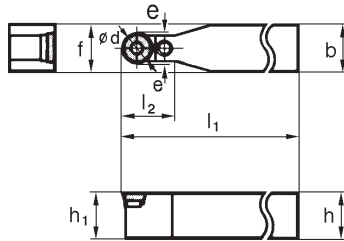
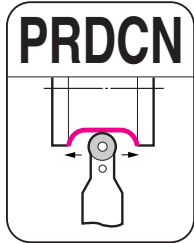

■ Inserts

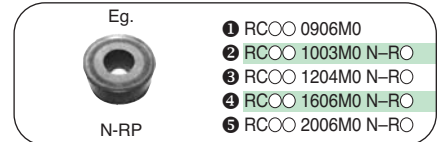

■ Spare Parts

Lever pin	Clamp screw	Shim	Shim pin	Wrench	Insert
LCL3S	LCS 3	LSR817	LSP3D	LH025	❶
LCL10	LCS10	LSR10	LSP10	LH020	❷
LCL12	LCS12	LSR12	LSP10	LH025	❸
LCL16	LCS16	LSR16	LSP16	LH025	❹
LCL20	LCS20	LSR20	LSP20	LH030	❺

■ Holders

Ordering No.	Stock	Dimensions (mm)							Lever pin	Clamp screw	Shim	Shim pin	Wrench	Insert
		h	h ₁	b	l ₁	l ₂	f	e						
PRDC N 3225 P9	○	32	32	25	170	25	12,5	0,5	LCL3S	LCS 3	LSR817	LSP3D	LH025	❶
PRDC N 2020 M10	●	20	20	20	150	22	15,0	1,0	LCL10	LCS10	LSR10	LSP10	LH020	❷
PRDC N 2525 M10	●	25	25	25	150	22	17,5	1,0	LCL10	LCS10	LSR10	LSP10	LH020	❷
PRDC N 2525 M12	●	25	25	25	150	24	18,5	1,2	LCL12	LCS12	LSR12	LSP10	LH025	❸
PRDC N 3225 Q12	●	32	32	25	180	24	18,5	1,2	LCL12	LCS12	LSR12	LSP10	LH025	❸
PRDC N 3225 Q16	●	32	32	25	180	28	20,5	1,5	LCL16	LCS16	LSR16	LSP16	LH025	❹
PRDC N 3232 Q20	●	32	32	32	180	32	26,0	1,7	LCL20	LCS20	LSR20	LSP20	LH030	❺

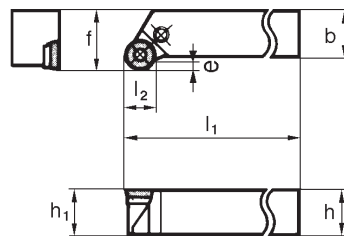
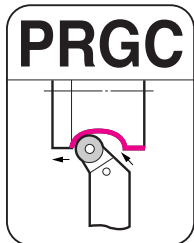

■ Inserts

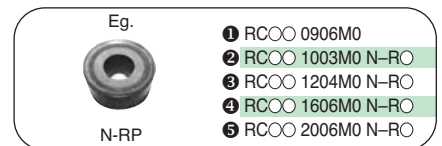

■ Spare Parts

Lever pin	Clamp screw	Shim	Shim pin	Wrench	Insert
LCL3S	LCS 3	LSR817	LSP3D	LH025	❶
LCL10	LCS10	LSR10	LSP10	LH020	❷
LCL12	LCS12	LSR12	LSP10	LH025	❸
LCL16	LCS16	LSR16	LSP16	LH025	❹
LCL20	LCS20	LSR20	LSP20	LH030	❺

■ Holders

Above figures show right hand tools.

Ordering No.	Stock		Dimensions (mm)							Lever pin	Clamp screw	Shim	Shim pin	Wrench	Insert
	R	L	h	h ₁	b	l ₁	l ₂	f	ød						
PRGC R/L 3225 P9	○	○	32	32	25	170	10	32	-	LCL3S	LCS 3	LSR817	LSP3D	LH025	❶
PRGC R/L 2020 K10	●	●	20	20	20	125	-	25	1,5	LCL10	LCS10	LSR10	LSP10	LH020	❷
PRGC R/L 2525 M10	●	●	25	25	25	150	-	32	1,5	LCL10	LCS10	LSR10	LSP10	LH020	❷
PRGC R/L 2020 K12	●	○	20	20	20	125	-	25	2,5	LCL10	LCS10	LSR10	LSP10	LH020	❷
PRGC R/L 2525 M12	○	●	25	25	25	150	-	32	2,5	LCL12	LCS12	LSR12	LSP10	LH025	❸
PRGC R/L 3225 P12	○	○	32	32	25	170	-	32	2,5	LCL12	LCS12	LSR12	LSP10	LH025	❸
PRGC R/L 2525 M16	●	○	25	25	25	150	-	32	3	LCL16	LCS16	LSR16	LSP16	LH025	❹
PRGC R/L 3225 P16	●	○	32	32	25	170	-	32	3	LCL16	LCS16	LSR16	LSP16	LH025	❹
PRGC R/L 3232 P20	●	○	32	32	32	170	-	40	4	LCL20	LCS20	LSR20	LSP20	LH030	❺

S Type Screw Lock Holders

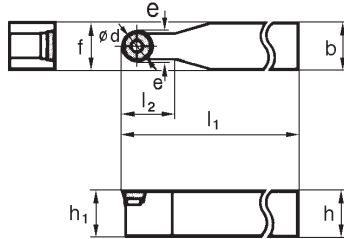
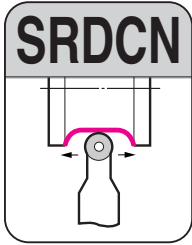

Inserts

Eg.  N-RX

- RCOO 1003M0
- ① RCOO 10T3M0 N-RO
- ② RCOO 1204M0 N-RO
- ③ RCOO 1606M0 N-RO
- ④ RCOO 2006M0 N-RO

■ Holders

Ordering No.	Stock	Dimensions (mm)						
		h	h ₁	b	l ₁	l ₂	f	e
New SRDC N 2020 K10T3	●	20	20	20	125	25	15,0	1,0
New SRDC N 2525 M10T3	●	25	25	25	150	25	17,5	1,0
SRDC N 2525 M12	●	25	25	25	150	28	18,5	1,2
SRDC N 3225 P12	●	32	32	25	170	28	18,5	1,2
SRDC N 2525 M16	○	25	25	25	150	35	20,5	1,5
SRDC N 3225 P16	●	32	32	25	170	35	20,5	1,5
SRDC N 3232 P16	○	32	32	32	170	35	20,5	1,5
SRDC N 3232 P20	●	32	32	32	170	40	26,0	1,7

■ Spare Parts

Screw	Shim	Screw	Wrench	Wrench	Insert
BFTX 03510-SD	SRNS 103-SD	BW 0508F-SD	TRX 15 IP-35	LH 035	①
BFTX 03512-SD	SRNS 123-SD				②
BFTX 0517-SD	SRNS 164-SD	BW 0810F-SD	LT 20 IP	LH 050	③
BFTX 0618-SD	SRNS 204-SD	BW 0912F-SD	LT 25 IP	LH 060	④

External Holders
for pos. Inserts

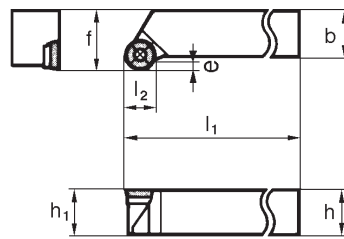
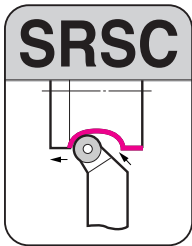

■ Inserts

Eg.  N-RX

- RCOO 1003M0
- ① RCOO 10T3M0 N-RO
- ② RCOO 1204M0 N-RO
- ③ RCOO 1606M0 N-RO
- ④ RCOO 2006M0 N-RO

■ Holders

Ordering No.	Stock		Dimensions (mm)						
	R	L	h	h ₁	b	l ₁	l ₂	f	e
New SRSC R/L 2020 K10T3	●	●	20	20	20	125	-	25	1,5
New SRSC R/L 2525 M10T3	●	●	25	25	25	150	-	32	1,5
SRSC R/L 2525 M12	●	●	25	25	25	150	-	32	2,5
SRSC R/L 3225 P12	●	●	32	32	25	170	-	32	2,5
SRSC R/L 2525 M16	○	○	25	25	25	150	-	32	3,0
SRSC R/L 3225 P16	●	●	32	32	25	170	-	32	3,0
SRSC R/L 3232 P16	○	○	32	32	32	170	-	40	3,0
SRSC R/L 3232 P20	●	●	32	32	32	170	-	40	4,0

■ Spare Parts

Screw	Shim	Screw	Wrench	Wrench	Insert
BFTX 03510-SD	SRNS 103-SD	BW 0508F-SD	TRX 15 IP-35	LH 035	①
BFTX 03512-SD	SRNS 123-SD				②
BFTX 0517-SD	SRNS 164-SD	BW 0810F-SD	LT 20 IP	LH 050	③
BFTX 0618-SD	SRNS 204-SD	BW 0912F-SD	LT 25 IP	LH 060	④

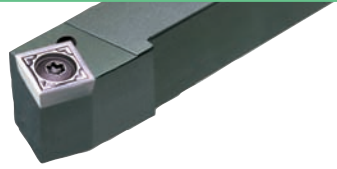

S Type Screw Lock Holders

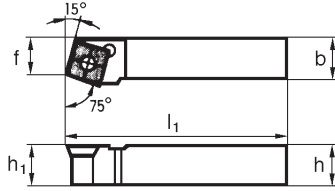
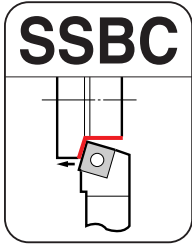

■ Inserts

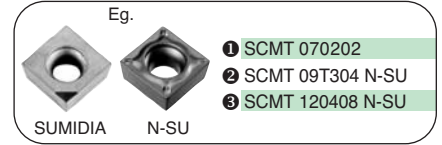

■ Spare Parts

Above figures show right hand tools.

Screw	Wrench	Insert
BFTX0307N	TRX10	1
BFTX0409N	TRX15	2
BFTX0511N	TRX20	3

■ Holders

Ordering No.	Stock		Dimensions (mm)							Screw	Wrench	Insert
	R	L	h	h ₁	b	l ₁	f					
SSBC R/L 1010 E07	○	○	10	10	10	70	9			BFTX0307N	TRX10	1
SSBC R/L 1212 F09	○	●	12	12	12	80	11			BFTX0409N	TRX15	2
SSBC R/L 1616 H09	●	●	16	16	16	100	13			BFTX0511N	TRX20	3
SSBC R/L 2020 K12	○	○	20	20	20	125	17					
SSBC R/L 2525 M12	○	○	25	25	25	150	22					

External Holders for pos. Inserts

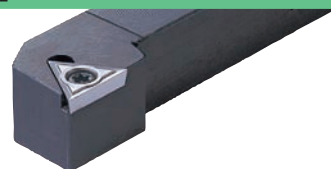

S Type Screw Lock Holders

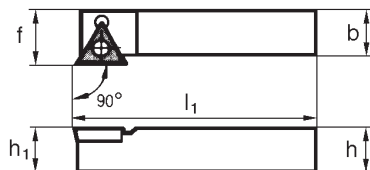
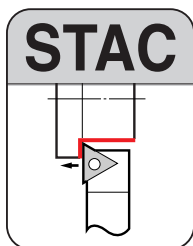

■ Holders

Above figures show right hand tools.

Ordering No.	Stock		Dimensions (mm)					Screw	Wrench	Insert
	R	L	h	h ₁	b	l ₁	f			
STAC R/L 0808 D09	●		8	8	8	60	8,5	BFTX02206N	TRX06	①
STAC R/L 1010 E09			10	10	10	70	10,5			②
STAC R/L 1212 F11	●	○	12	12	12	80	12,5	BFTX02506N	TRX08	②

■ Inserts

Eg.

- ① TCMT 090202 N-FP
- ② TCMT 110204 N-SU

■ Spare Parts

Screw	Wrench	Insert
BFTX02206N	TRX06	①
BFTX02506N	TRX08	②

External Holders
for pos. inserts

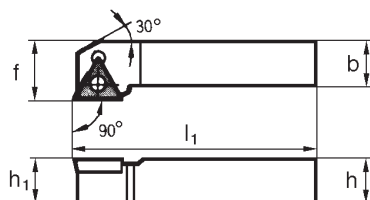
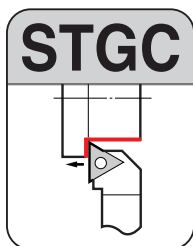

■ Holders

Above figures show right hand tools.

Ordering No.	Stock		Dimensions (mm)					Screw	Wrench	Insert
	R	L	h	h ₁	b	l ₁	f			
STGC R/L 0808 D09	○		8	8	8	60	10	BFTX02206N	TRX06	①
STGC R/L 1010 E09	●	●	10	10	10	70	12			②
STGC R/L 1212 F11	●	●	12	12	12	80	16	BFTX02506N	TRX08	②
STGC R/L 1616 H11	●	●	16	16	16	100	20			③
STGC R/L 1616 H16	●	●	16	16	16	100	20	BFTX0409N	TRX15	③
STGC R/L 2020 K16	●	●	20	20	20	125	25			③
STGC R/L 2525 M16	○	○	25	25	25	150	32	BFTX0511N	TRX20	
STGC R/L 2525 M22	○	○	25	25	25	150	32			

■ Inserts

Eg.

- ① TCMT 090202 N-FP
- ② TCMT 110204 N-SU
- ③ TCMT 16T308 N-SU

■ Spare Parts

Screw	Wrench	Insert
BFTX02206N	TRX06	①
BFTX02506N	TRX08	②
BFTX0409N	TRX15	③
BFTX0511N	TRX20	

External Mini Tool Holders SV Type

Mini Holders for 5° VB__ pos. Inserts

S Type Screw Lock Holders

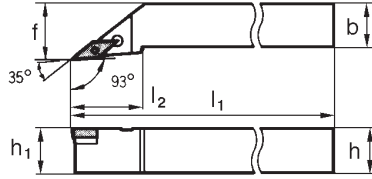
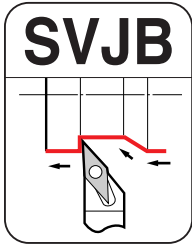
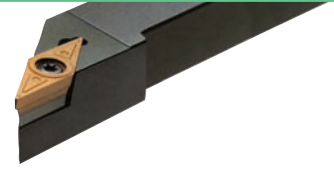

■ Holders

Above figures show right hand tools.

Ordering No.	Stock		Dimensions (mm)						Stopper	Nut	Shim	Wrench	Scew	Wrench	Insert
	R	L	h	h ₁	b	l ₁	l ₂	f							
SVJB R/L 1212 F11	●	●	12	12	12	80	25	16	-	-	-	-	BFTX 02506N	TRX08	①
SVJB R/L 1616 H11	●	●	16	16	16	100	25	20	-	-	-	-	BFTX 02506N	TRX08	①
SVJB R/L 2020 K16	●	●	20	20	20	125	41	25	VP20	-	-	-	BFTX 02506N	TRX08	①
SVJB R/L 2525 M16	●	●	25	25	25	150	41	32	VP25	CPV33N	SVP32	LH025	BFTX 03508	TRX10	②
SVJB R/L 3225 P16	●	●	32	32	25	170	41	32	VP32	-	-	-	BFTX 03508	TRX10	②

■ Inserts



■ Spare Parts

Stopper	Nut	Shim	Wrench	Scew	Wrench	Insert
VP20	-	-	-	BFTX 02506N	TRX08	①
VP25	CPV33N	SVP32	LH025	BFTX 03508	TRX10	②
VP32	-	-	-	BFTX 03508	TRX10	②

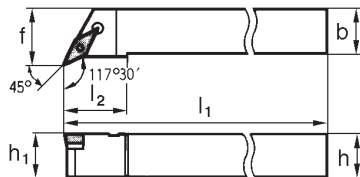
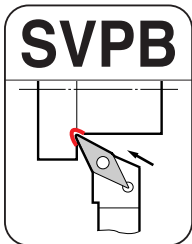

■ Holders

Above figures show right hand tools.

Ordering No.	Stock		Dimensions (mm)						Stopper	Nut	Shim	Wrench	Scew	Wrench	Insert
	R	L	h	h ₁	b	l ₁	l ₂	f							
SVPB R/L 1212 F11	●	○	12	12	12	80	25	16	-	-	-	-	BFTX 02506N	TRX08	①
SVPB R/L 1616 H11	●	●	16	16	16	100	25	20	-	-	-	-	BFTX 02506N	TRX08	①
SVPB R/L 2020 K16	●	●	20	20	20	125	36	25	VP20	-	-	-	BFTX 02506N	TRX08	①
SVPB R/L 2525 M16	●	●	25	25	25	150	36	32	VP25	CPV33N	SVP32	LH025	BFTX 03508	TRX10	②
SVPB R/L 3225 P16	●	●	32	32	25	170	36	32	VP32	-	-	-	BFTX 03508	TRX10	②

■ Inserts



■ Spare Parts

Stopper	Nut	Shim	Wrench	Scew	Wrench	Insert
VP20	-	-	-	BFTX 02506N	TRX08	①
VP25	CPV33N	SVP32	LH025	BFTX 03508	TRX10	②
VP32	-	-	-	BFTX 03508	TRX10	②

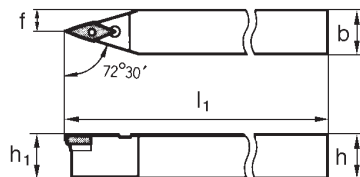
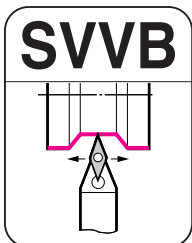

■ Holders

Ordering No.	Stock	Dimensions (mm)						Stopper	Nut	Shim	Wrench	Scew	Wrench	Insert
		h	h ₁	b	l ₁	l ₂	f							
SVVB N 1212 F11	●	12	12	12	80	-	6	-	-	-	-	BFTX 02506N	TRX08	①
SVVB N 1616 H11	●	16	16	16	100	-	8	-	-	-	-	BFTX 02506N	TRX08	①
SVVB N 2020 K16	●	20	20	20	125	-	10	VP20	-	-	-	BFTX 02506N	TRX08	①
SVVB N 2525 M16	●	25	25	25	150	-	12,5	VP25	CPV33N	SVP32	LH025	BFTX 03508	TRX10	②
SVVB N 3225 P16	●	32	32	25	170	-	12,5	VP32	-	-	-	BFTX 03508	TRX10	②

■ Inserts



■ Spare Parts

Stopper	Nut	Shim	Wrench	Scew	Wrench	Insert
VP20	-	-	-	BFTX 02506N	TRX08	①
VP25	CPV33N	SVP32	LH025	BFTX 03508	TRX10	②
VP32	-	-	-	BFTX 03508	TRX10	②

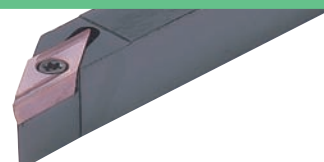

S Type Screw Lock Holders

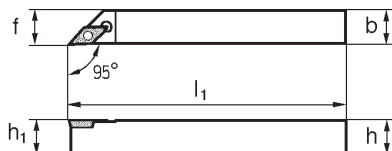
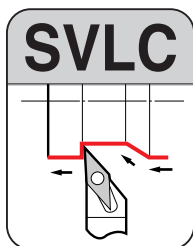

■ Inserts



■ Spare Parts

■ Holders

Above figures show right hand tools.

Ordering No.	Stock		Dimensions (mm)						Screw	Wrench	Insert
	R	L	h	h ₁	b	l ₁	f				
SVLC R/L 1010 H11	●	●	10	10	10	100	10,5				
SVLC R/L 1212 H11	●	●	12	12	12	100	12,5	BFTX02506N	TRX08	①	
SVLC R/L 1616 H11	●	●	16	16	16	100	16,5				
SVLC R/L 2525 M11	●		25	25	25	150	25,5				

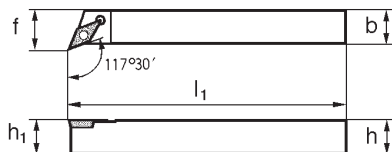
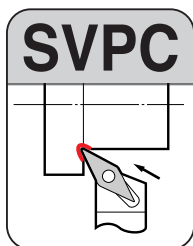

■ Inserts



■ Spare Parts

■ Holders

Above figures show right hand tools.

Ordering No.	Stock		Dimensions (mm)						Screw	Wrench	Insert
	R	L	h	h ₁	b	l ₁	f				
SVPC R/L 1010 H11	○	○	10	10	10	100	14,5				
SVPC R/L 1212 H11	●	●	12	12	12	100	16,5	BFTX02506N	TRX08	①	
SVPC R/L 1616 H11	●	●	16	16	16	100	20,5				

External Holders
for pos. Inserts

